

English

Safety measures

To ensure a correct and safe installation of the dock shelter please take the following measures:

- always follow the applicable safety guidelines.
- only use approved tools/instruments.
- please follow the installation steps in the sequence as they are mentioned in the installation drawings.
- When replacing damaged parts only use original parts. Otherwise the correct function of the dock shelter cannot be guaranteed. Besides this the warranty will expire.



BEWARE!

failure to comply to these measures can cause serious damage to persons or materials!

Deutsch

Sicherheitsmaßnahmen

Im Hinblick auf eine korrekte und sichere Montage der Torabdichtung ist folgendes zu beachten:

- bitte beachten Sie die geltenden Sicherheitsvorschriften
- Verwenden Sie nur ordnungsgemäßes Werkzeug.
- Führen Sie die Montageschritte in der Reihenfolge die in den Montagezeichnungen angegeben sind durch.
- Verwenden Sie beim Austausch beschädigter Teile nur Originalersatzteile. Anderenfalls ist die ordnungsgemäße Funktion der Torabdichtung nicht gewährleistet. Außerdem verfällt der Garantieanspruch.



ACHTUNG!

Nichtbeachtung dieser Maßnahmen können ernsthafte Personen- oder Materialschäden zur Folge haben!

Français

Mesures de sécurité :

Pour assurer une installation correcte en toute sécurité de sas d'étanchéité, les règles suivantes devront être suivies :

- respecter toujours les règles de sécurité élémentaire,
- utiliser que des outils appropriés,
- respecter la méthodologie de pose définie dans le manuel d'installation,
- Ne remplacer les pièces endommagées que par des pièces d'origine. Le non respect de cette procédure ne permet plus de garantir le fonctionnement correct de sas d'étanchéité et la garantie du fabricant ne sera plus applicable.



ATTENTION :

Le non-respect de l'une de ces procédures peut engendré de sérieux dommages corporels ou matériels!

Nederlands

Veiligheidsmaatregelen







Om een veilige en correcte montage van de dockshelter te kunnen waarborgen dienen de volgende maatregelen te worden genomen:

- volg ten alle tijden de geldende veiligheidsvoorschriften.
- gebruik alleen goedgekeurd gereedschap.
- hanteer nauwkeurig de montagevolgorde conform de montagetekeningen.
- Gebruik voor het uitwisselen van beschadigde onderdelen alleen originele onderdelen. Indien er geen originele onderdelen worden gebruikt kan de oordelijke functie van de dockshelter niet worden gewaarborgt. Bovendien vervalt de garantie.



LET OP!

niet naleving van deze maatregelen kan ernstige persoonlijke- of materiele schade tot gevolg hebben!

	English	Deutsch	Français	Nederlands
	Attention: danger	Achtung: Gefahr	Attention:	Opgelet: gevaar
	In conformity with local legislation	Konform Lokale Gesetzgebung	Conforme législation local	Conform lokale wetgeving
	See alternative(s)	Siehe alternative	... alternative	Zie alternatief
	Alternative	Alternative	Alternative	Alternatief
	Measure	Meßen	Mesurer	Meten
	Tightening moment	Anzugsmoment	Moment de serrage	Aanhaalmoment

	Steel frame	Stahlrahmen	Constructio n en acier	Staalframe
--	-------------	-------------	---------------------------	------------



Welding	Schweißen	Soudé	Lassen
---------	-----------	-------	--------

Selfdrilling screw 8 x 25	Selbstschne idende Schraube 8 x 25	Vis Autoperceu se 8 x 25	Plaatschroef f 8 x 25
---------------------------------	---	-----------------------------------	-----------------------------

	Insulated cladding	Trapezblechfass ade (Holz)	Partage double peau (bois)	Binnendooscon structie (hout)
--	-----------------------	-------------------------------	-------------------------------	----------------------------------

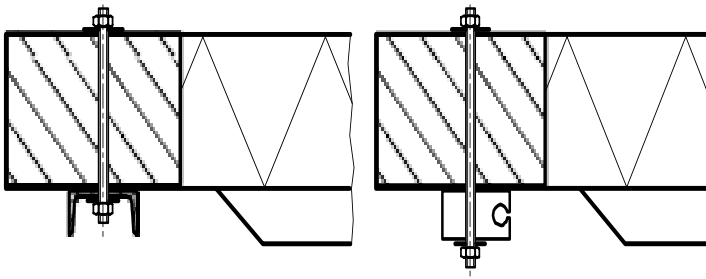

Hexagon head bolt M8	Sechskantb olzen M8	Boulon à tête hexagonale M8	Zeskantbout M8
Stud M8	Gewindesta nge M8	Embout fileté M8	Draadeind M8

	Concrete	Beton	Béton	Beton
--	----------	-------	-------	-------

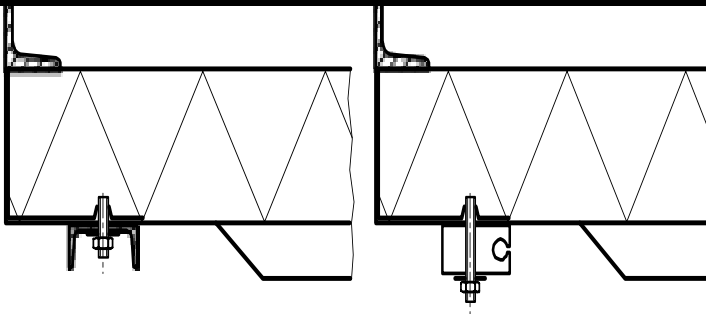

min 25 N/ mm ²	min 25 N/ mm ²	min 25 N/ mm ²	min 25 N/ mm ²
Wedge- anchor M8 x 75	Keilanker M8 x 75	Chevilles mécaniques M8 x 75	Keilanker M8 x 75

	Insulation panels/ light-weight concrete	Sandwichplatten/ Leichtgewicht beton	Panneaux isolants/ Béton léger	ISO paneel / lichtgewicht beton
--	--	--	-----------------------------------	------------------------------------

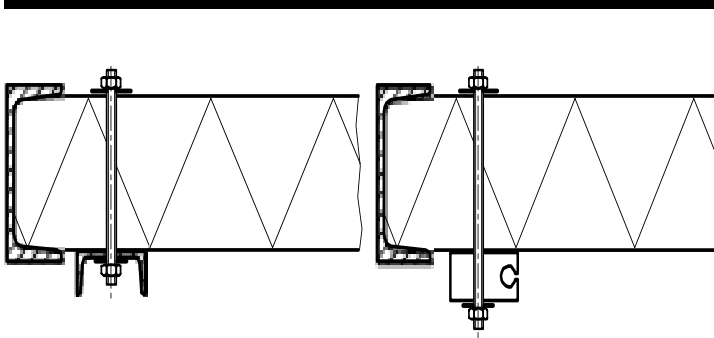

Hexagon head bolt M8	Sechskantb olzen M8	Boulon à tête hexagonale M8	Zeskantbout M8
Stud M8	Gewindesta nge M8	Embout fileté M8	Draadeind M8

2.1.01

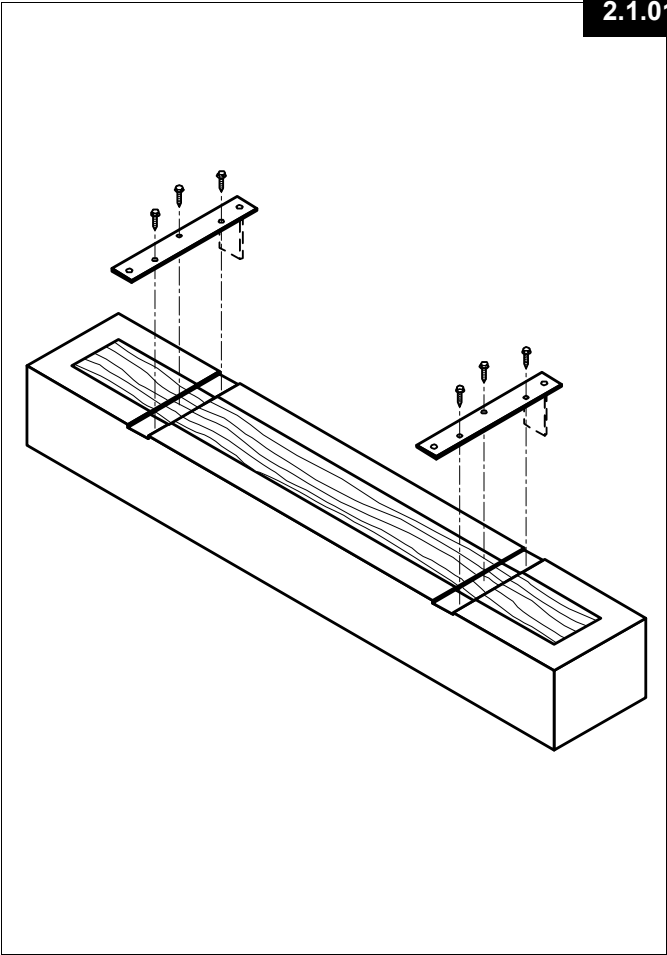

2.1.02

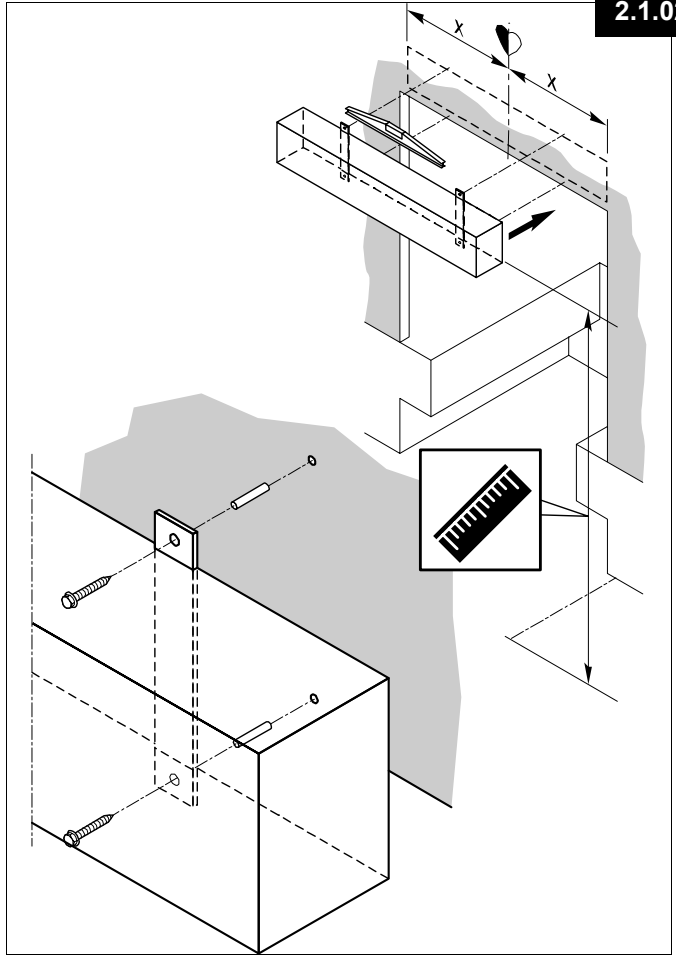

2.1.03

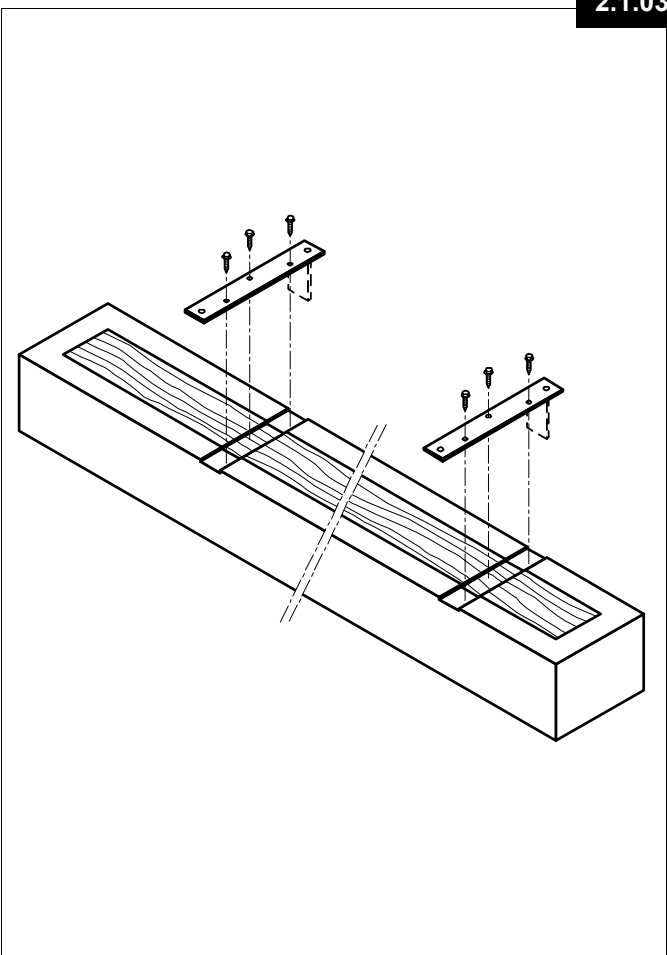

2.1.04

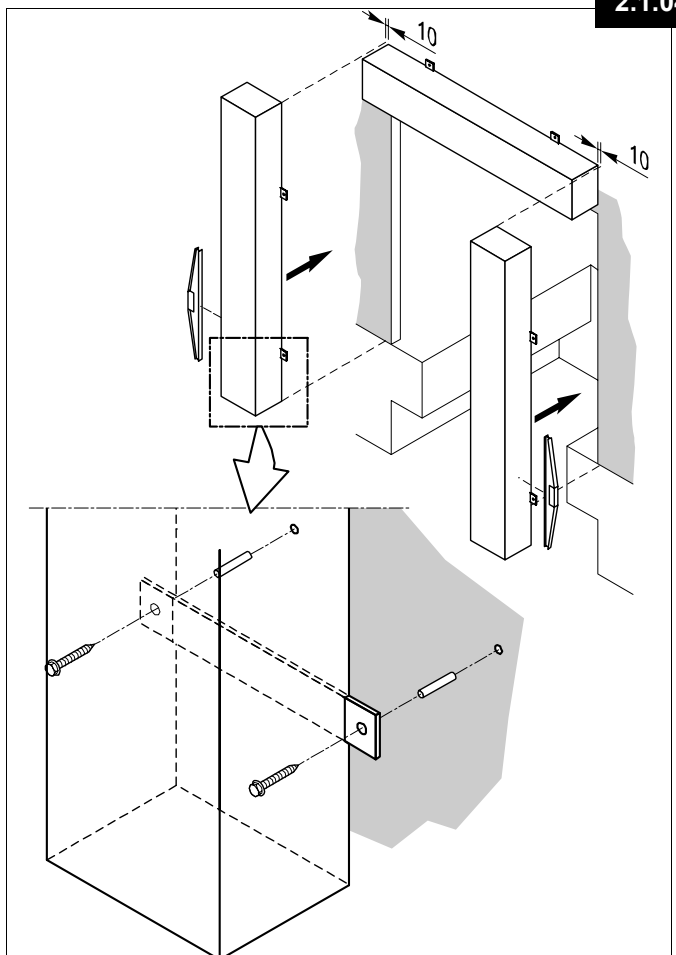

2.2.01

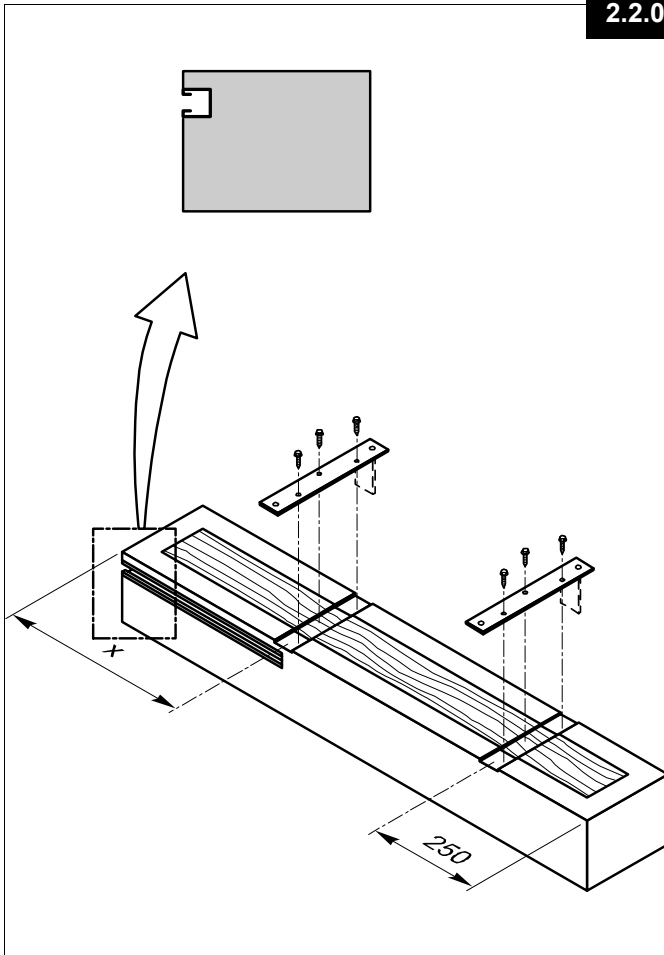

2.2.02

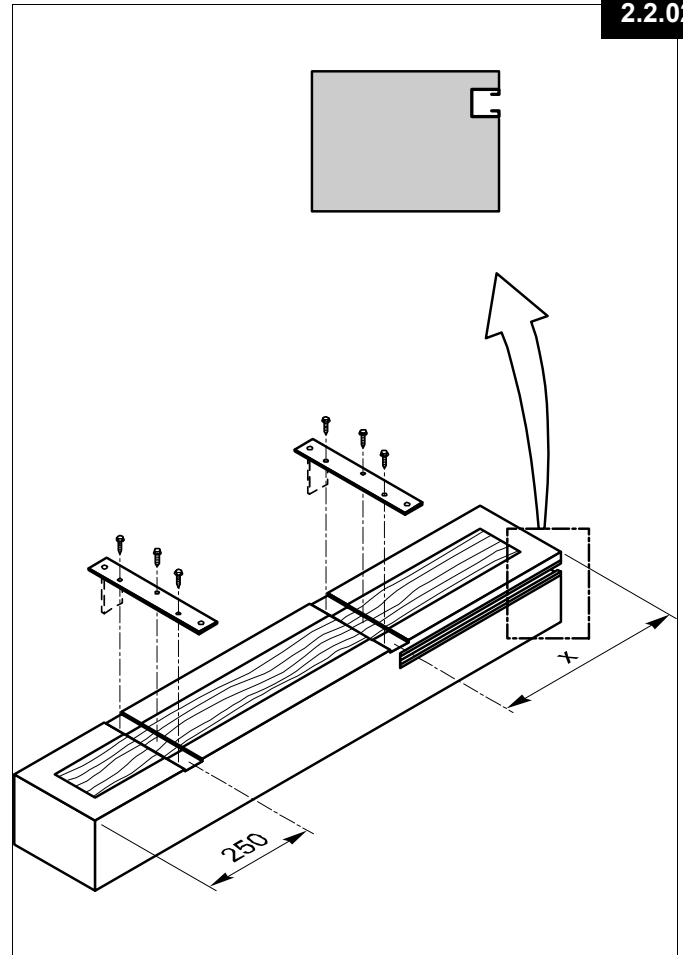

2.2.03

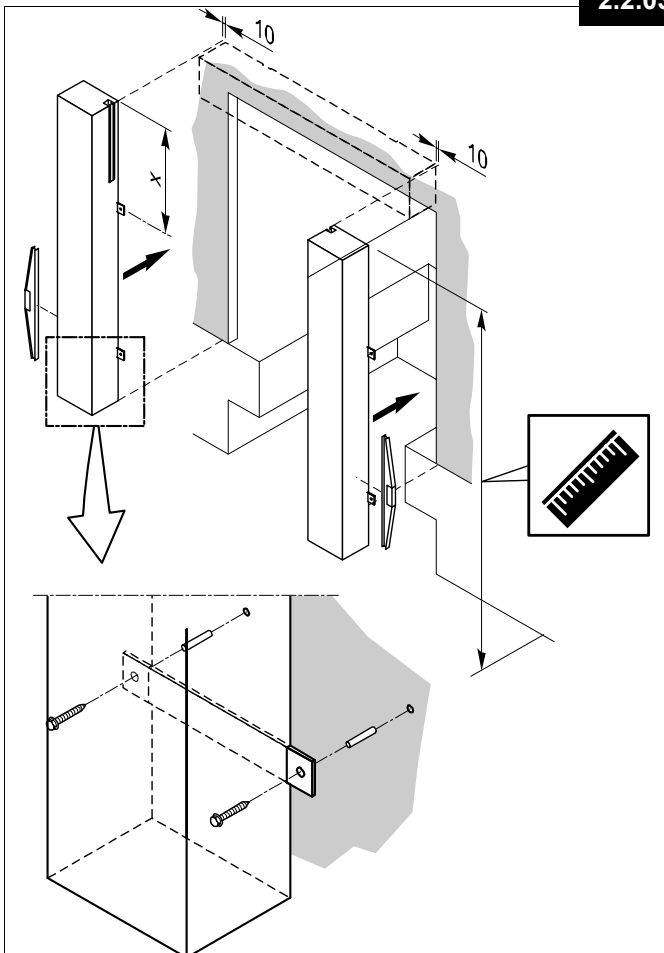

2.2.04

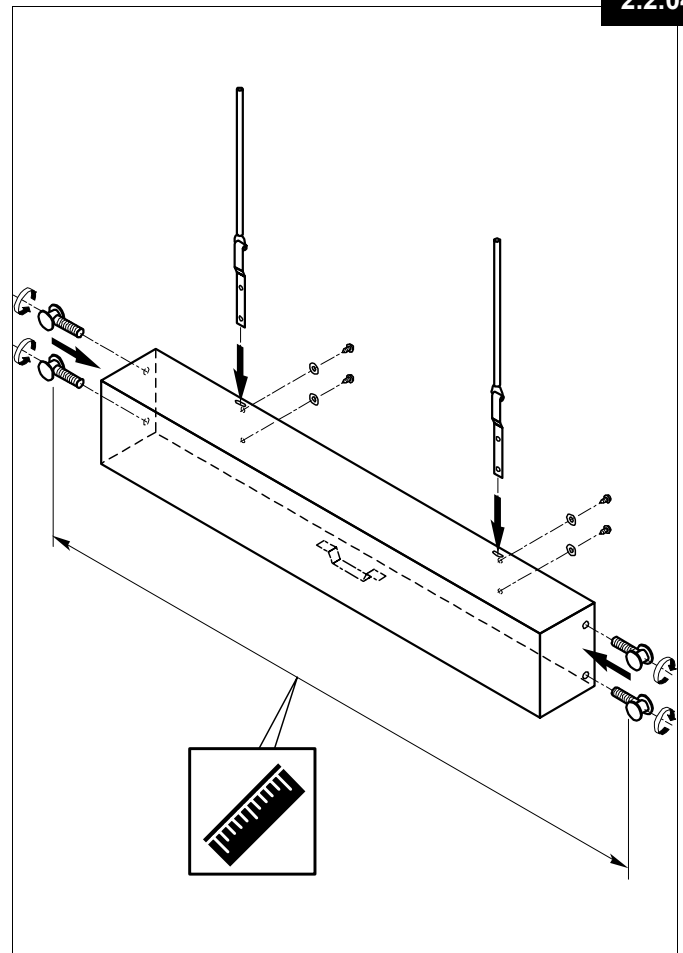

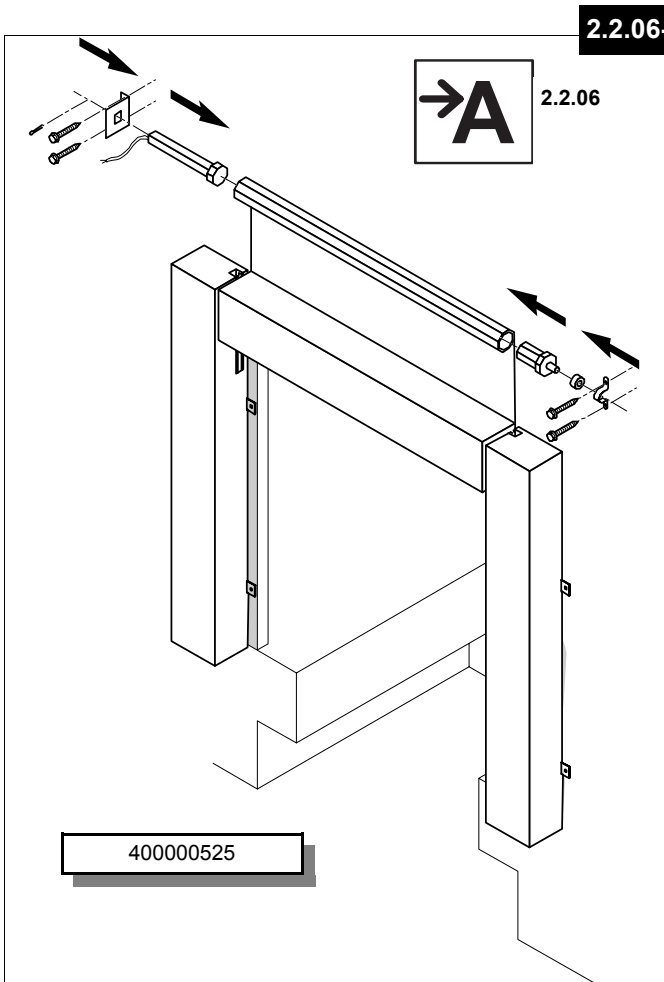
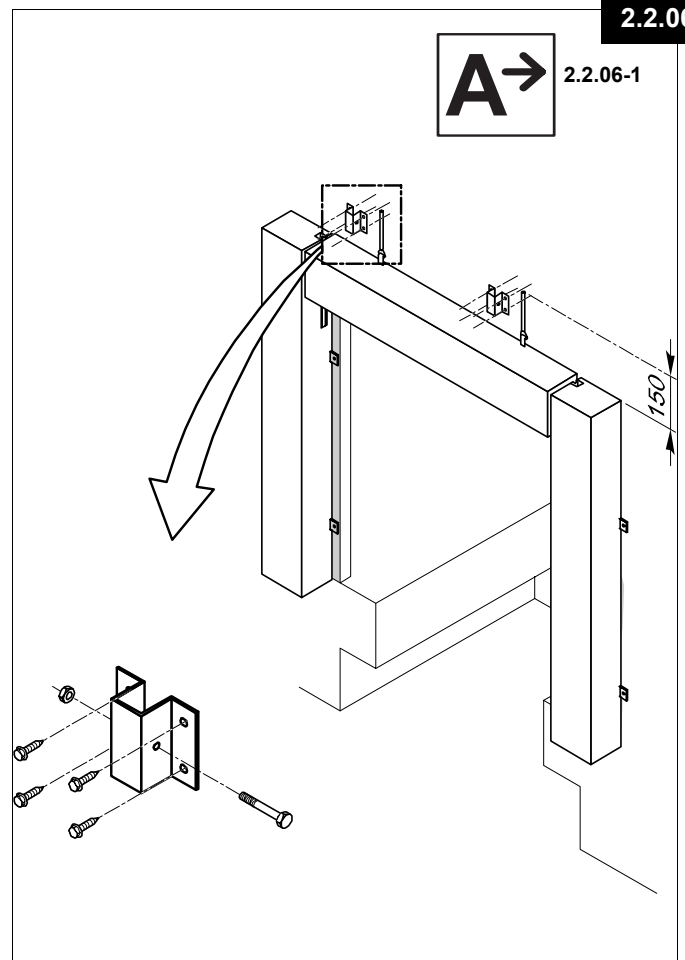
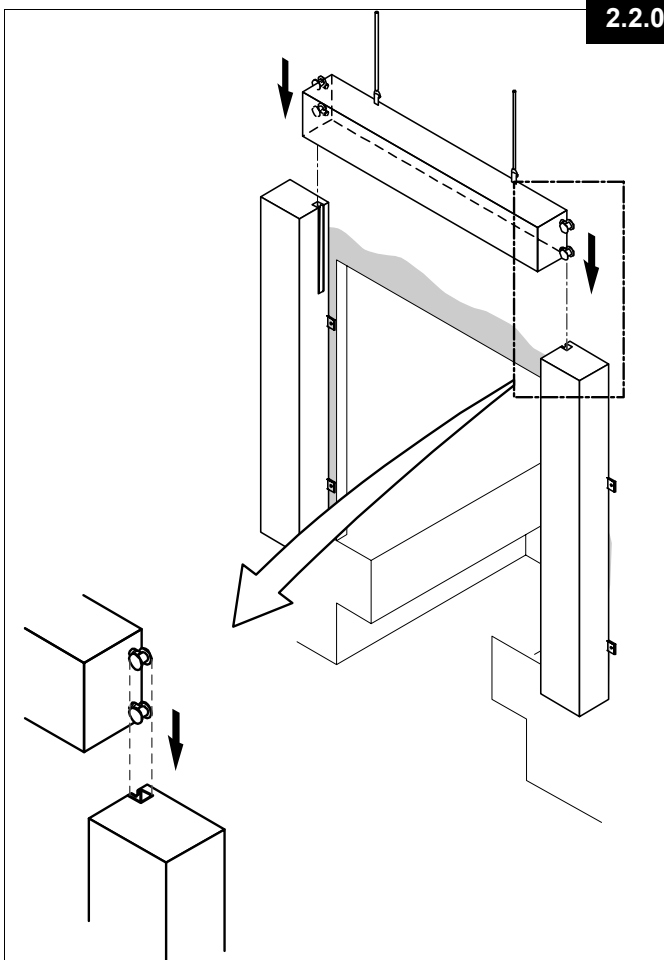

3.1.01

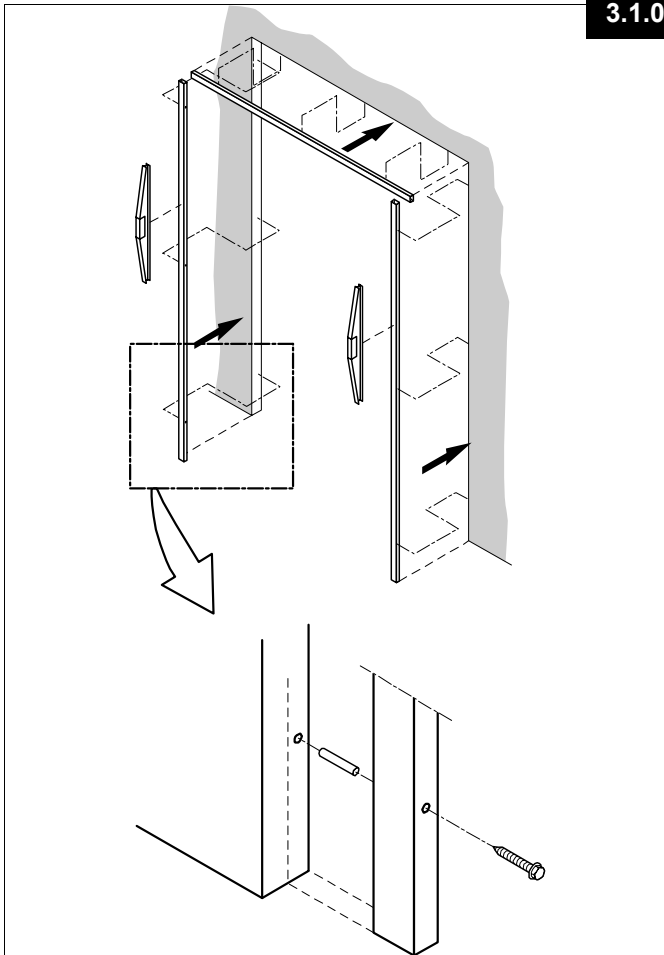

3.1.02

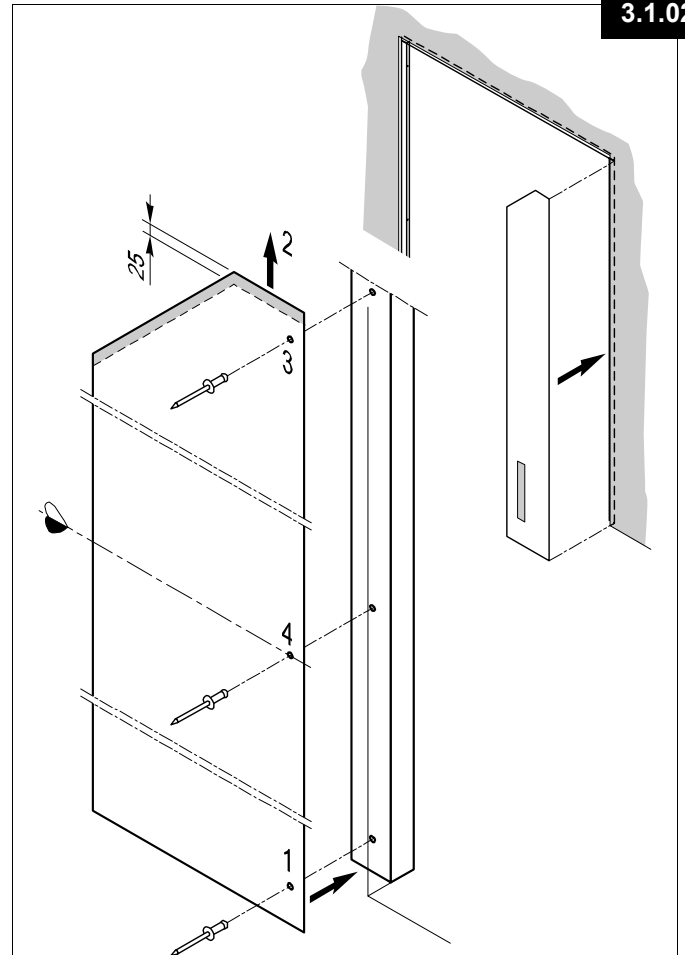

3.1.03

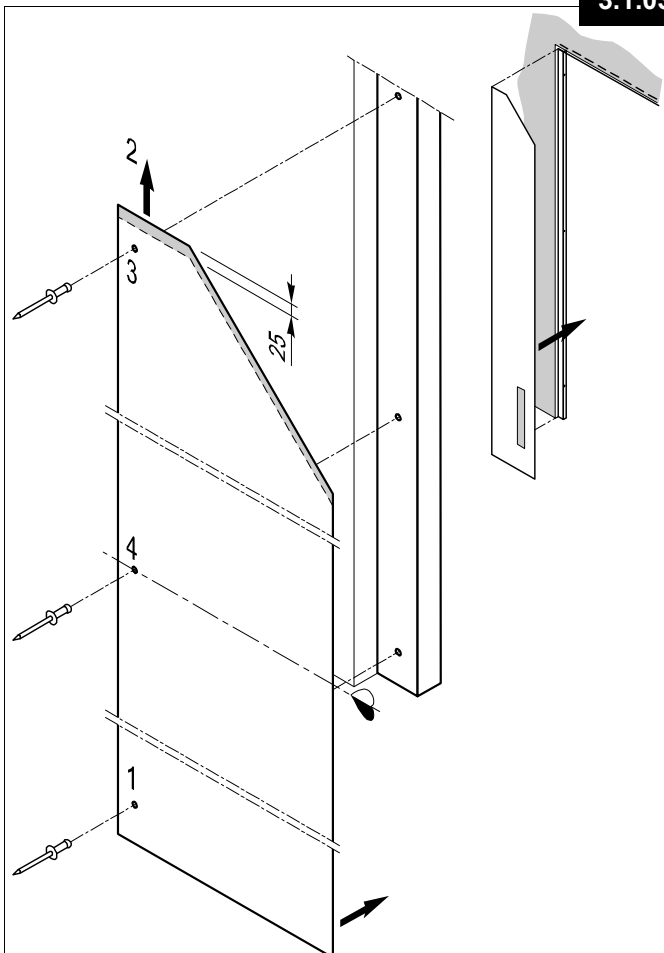

3.1.04

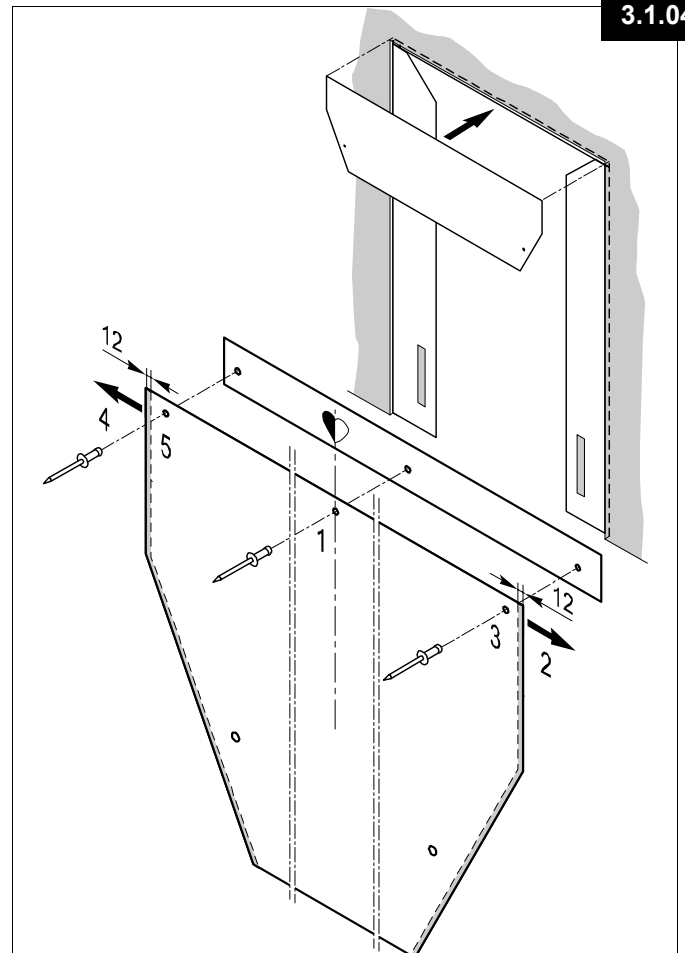

3.1.05

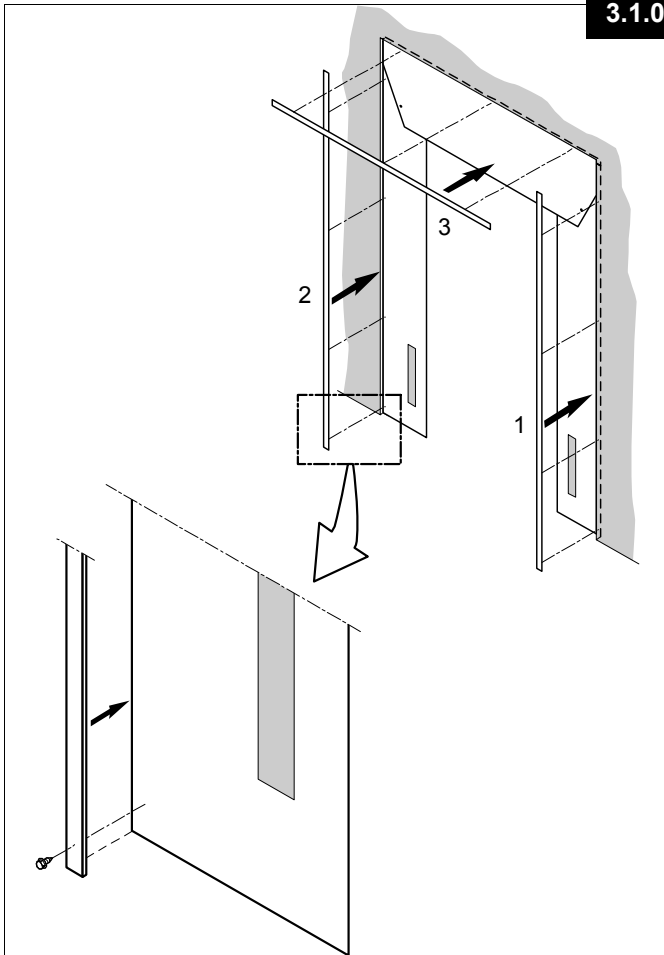

3.1.06

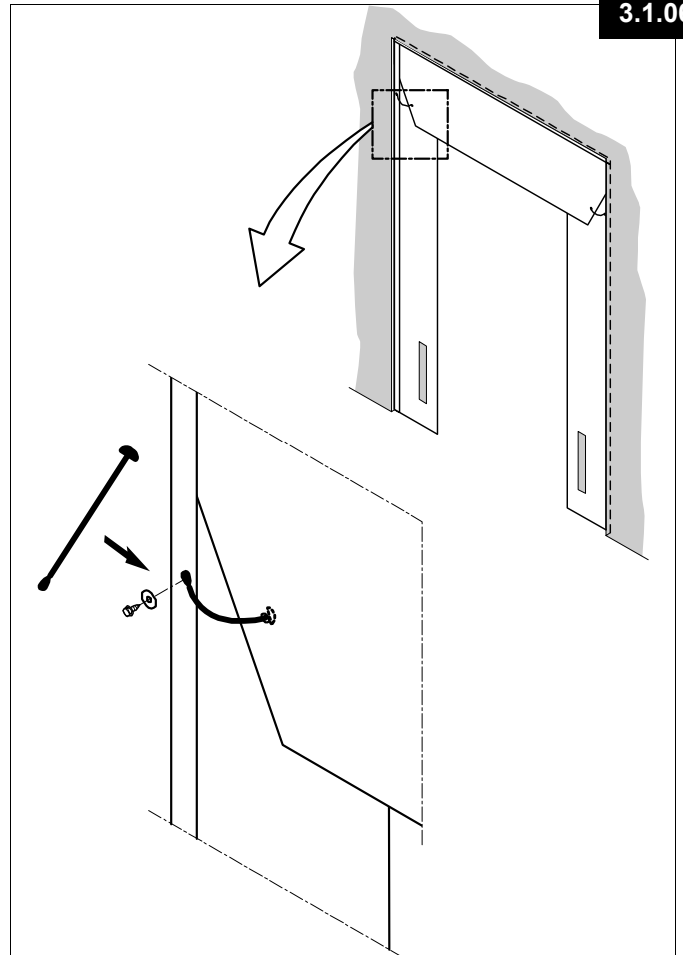

3.1.07

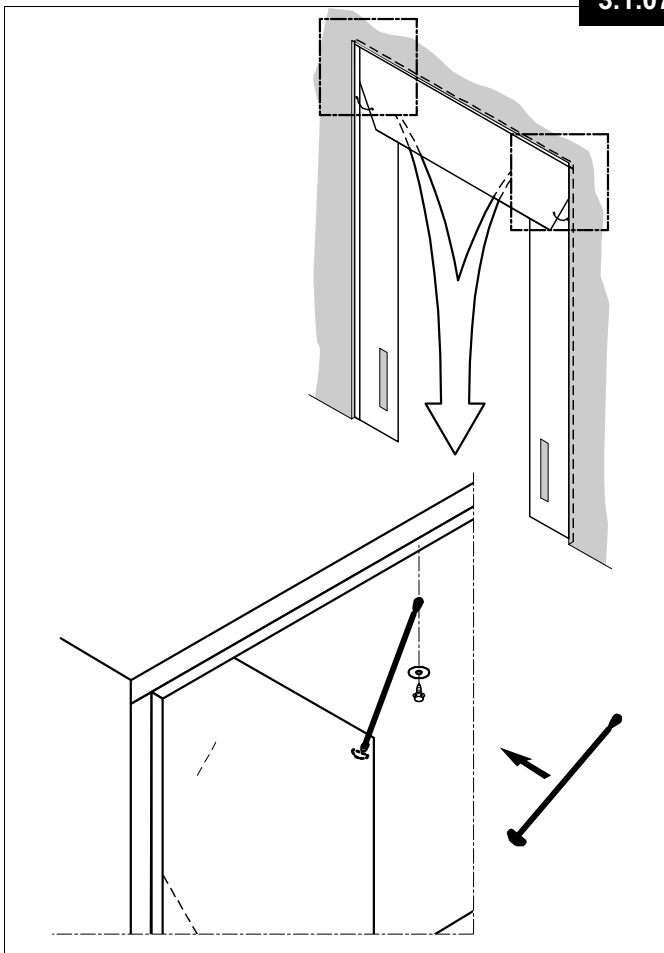

3.2.01

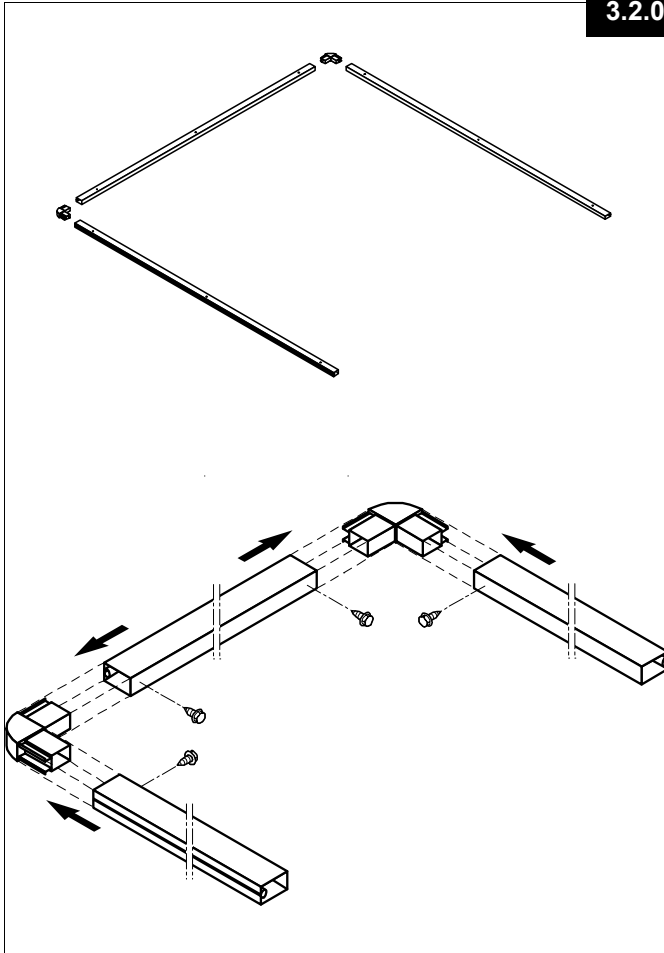

3.2.02

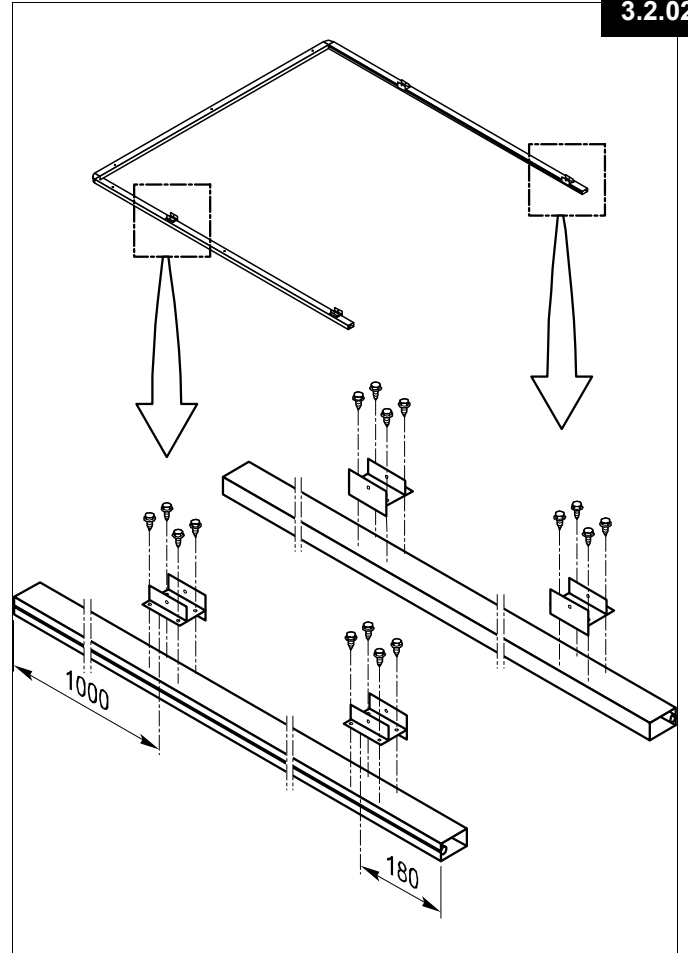

3.2.03

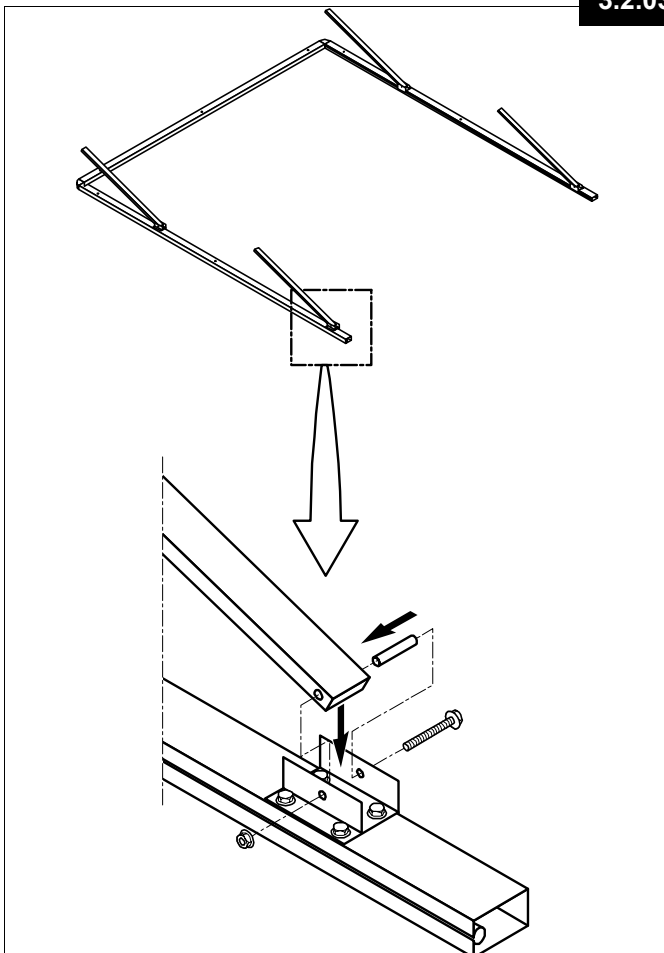

3.2.04

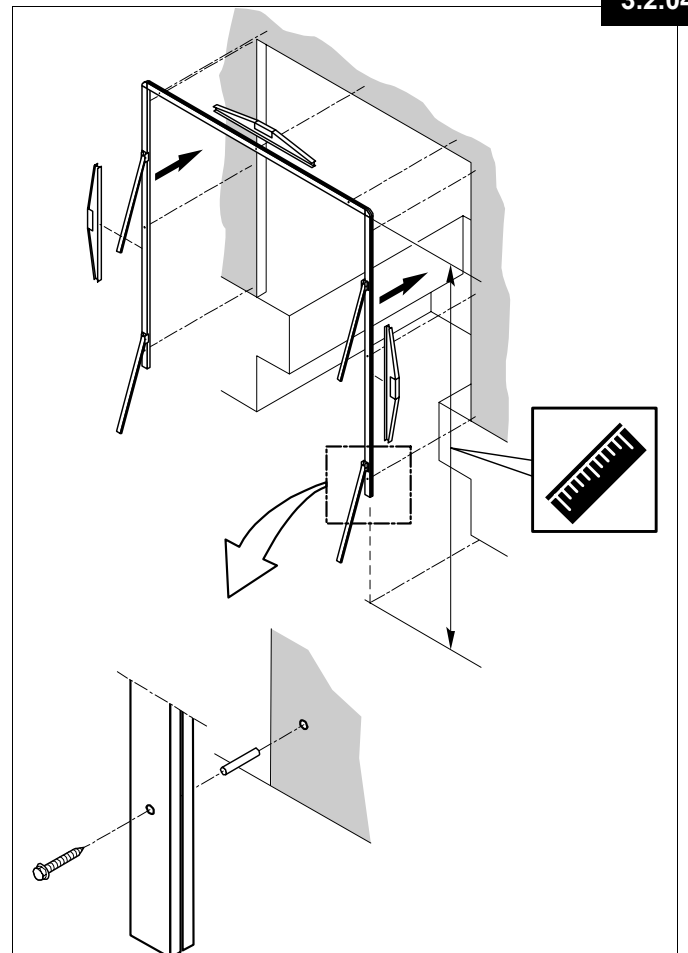

3.2.05

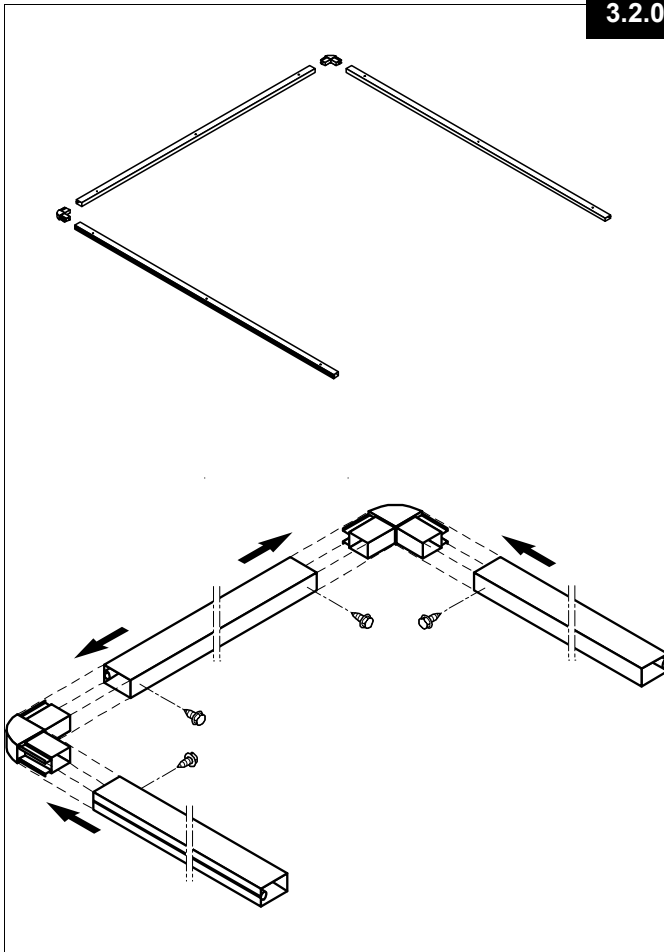

3.2.06

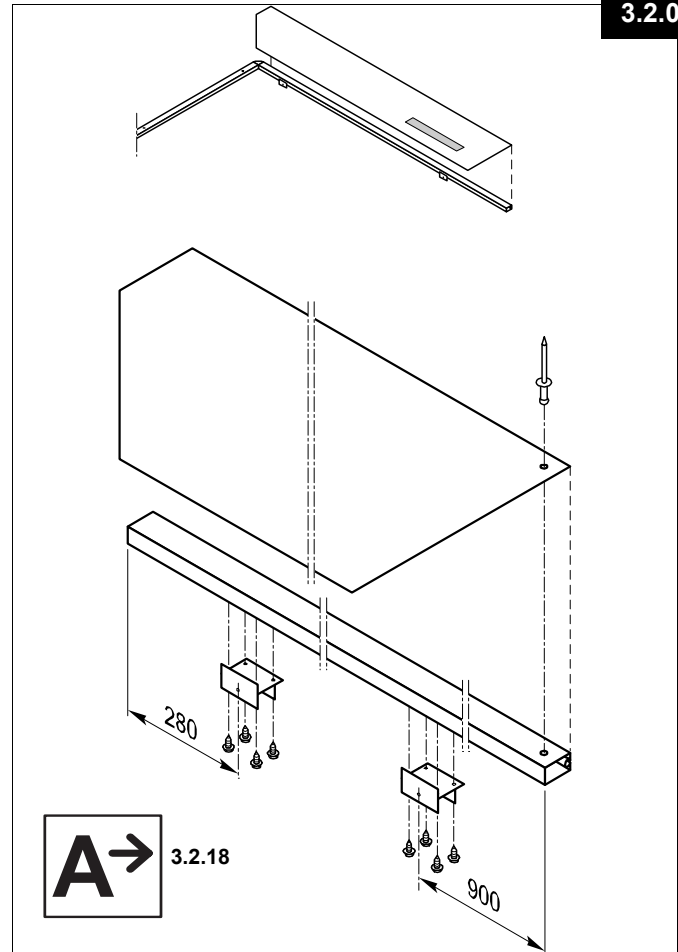

3.2.07

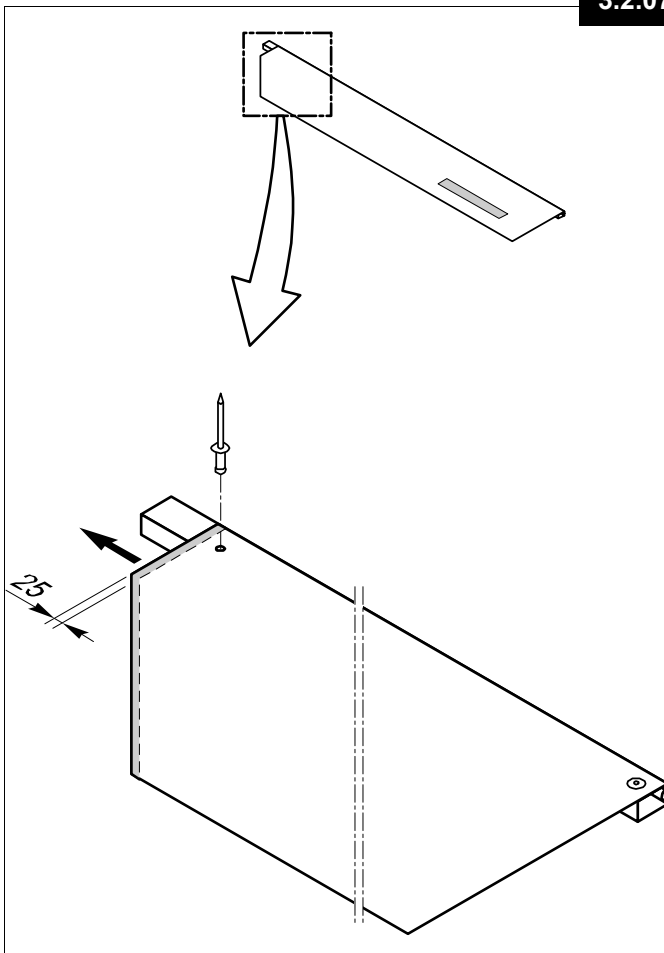

3.2.08

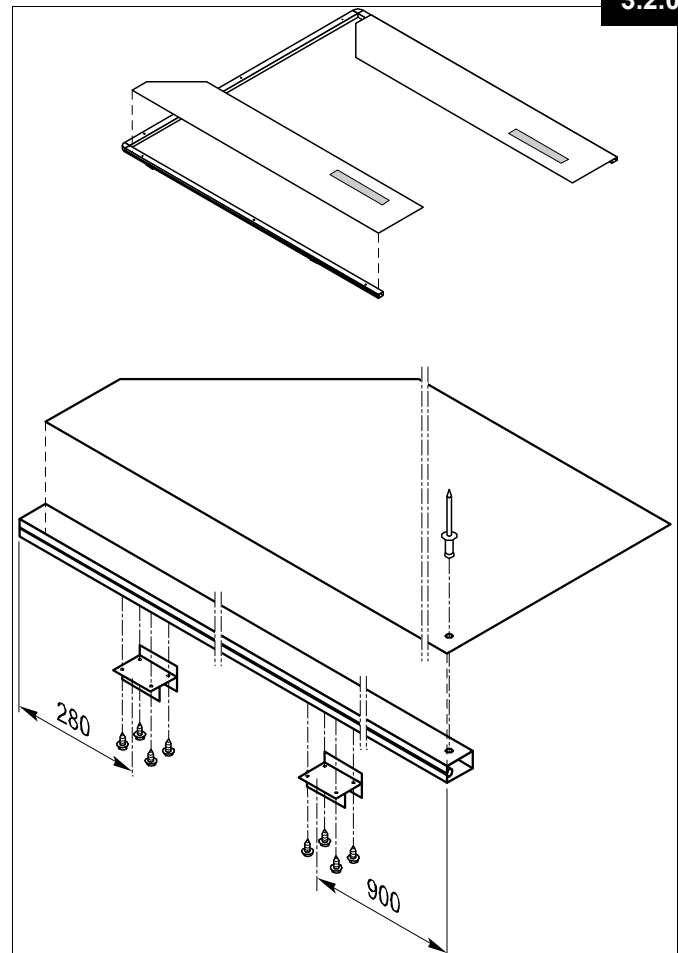

3.2.13

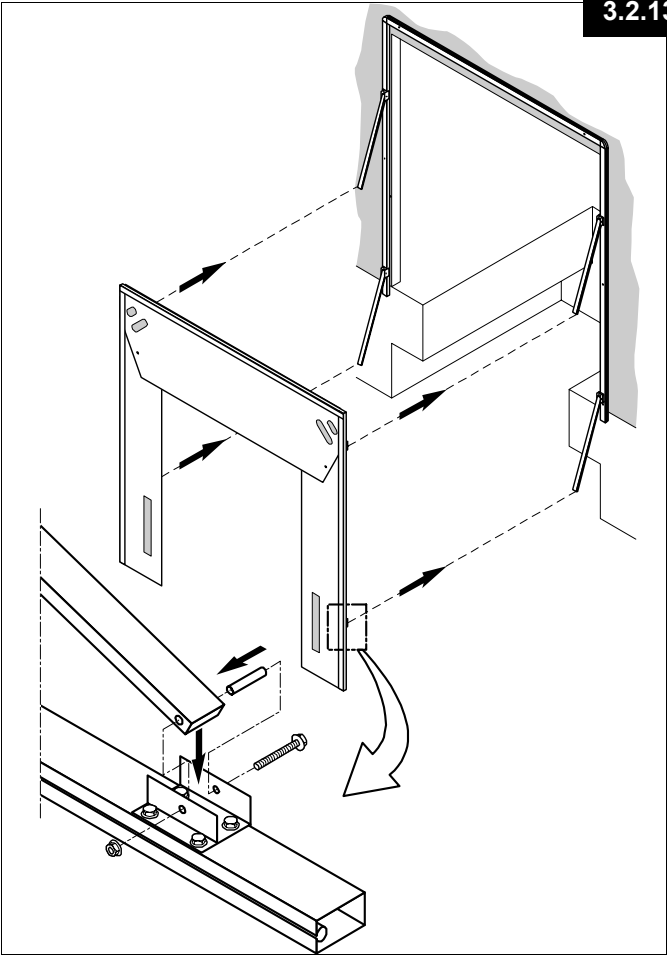

3.2.14

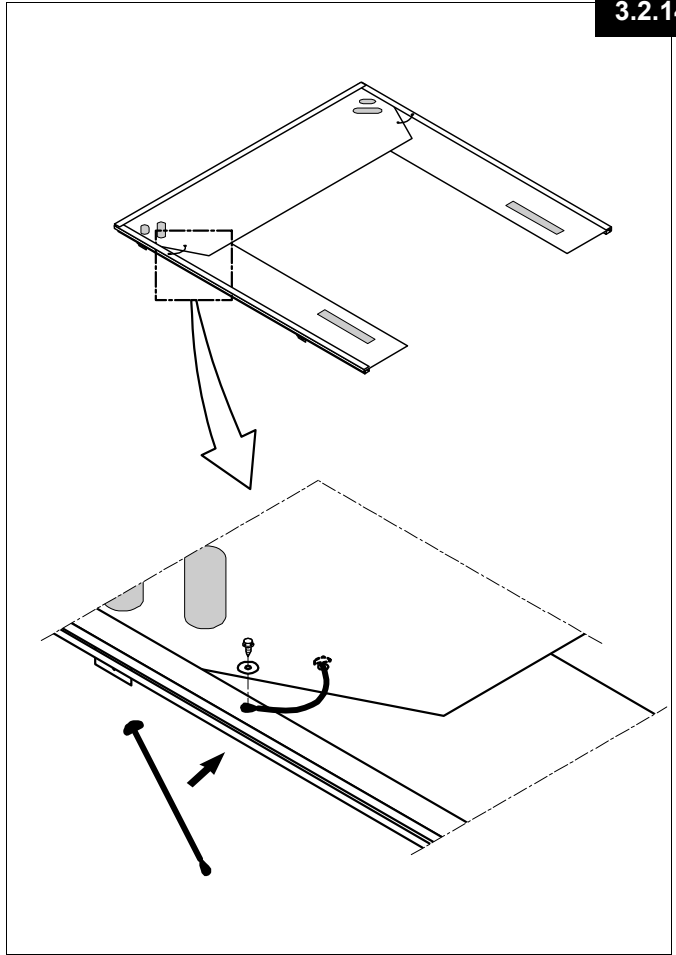

3.2.15

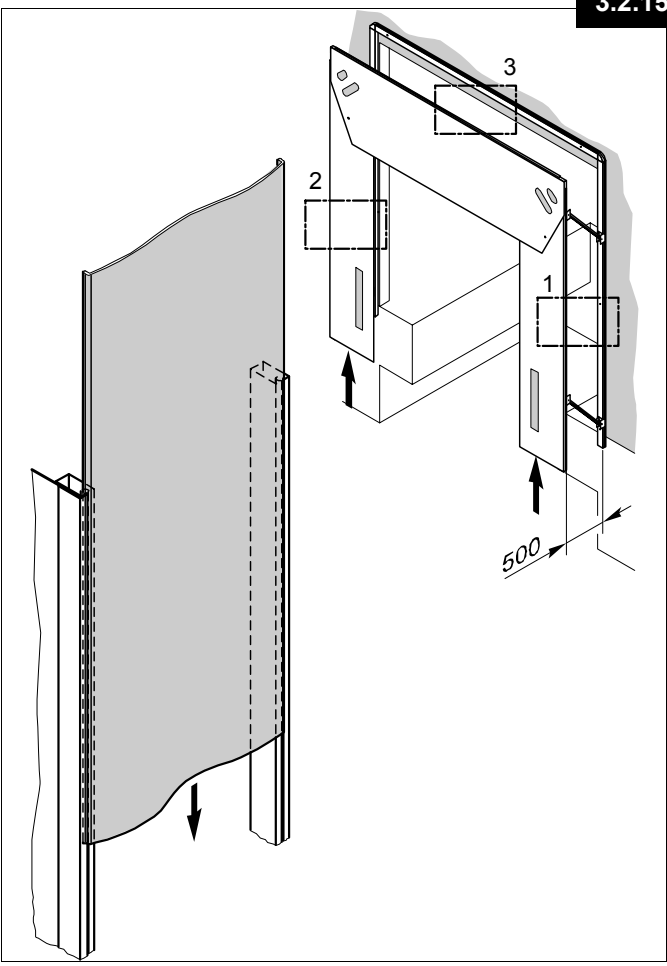

3.2.16

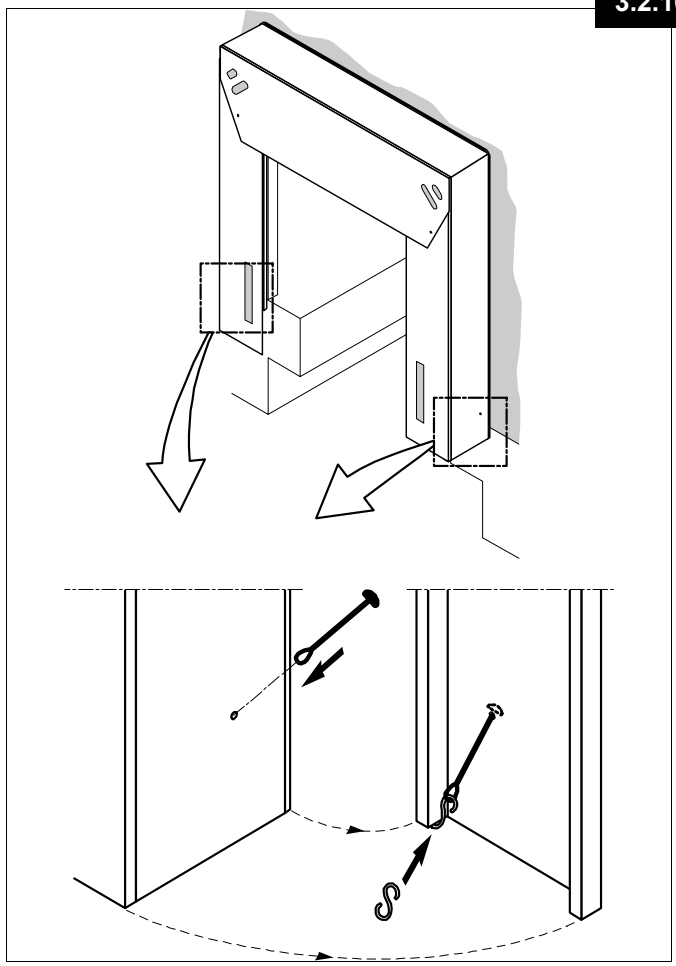

3.2.17

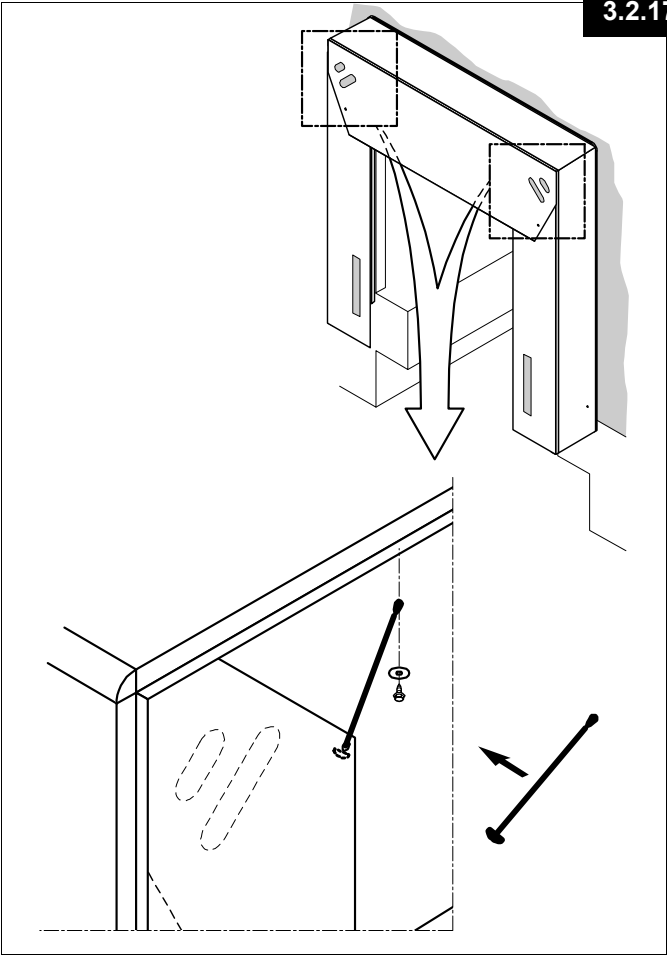

3.2.18

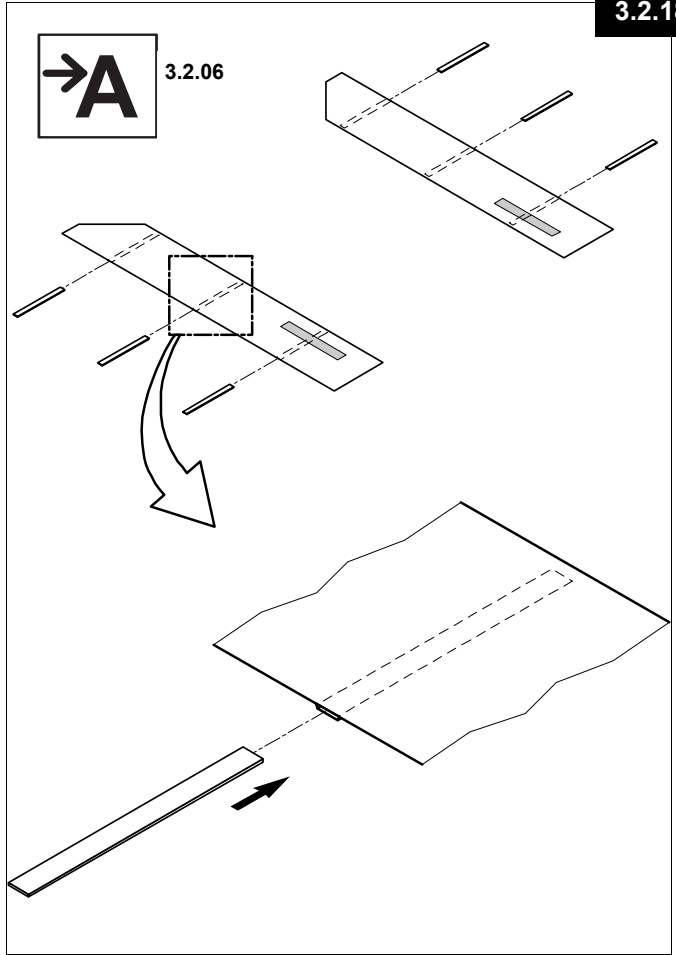

3.2.19

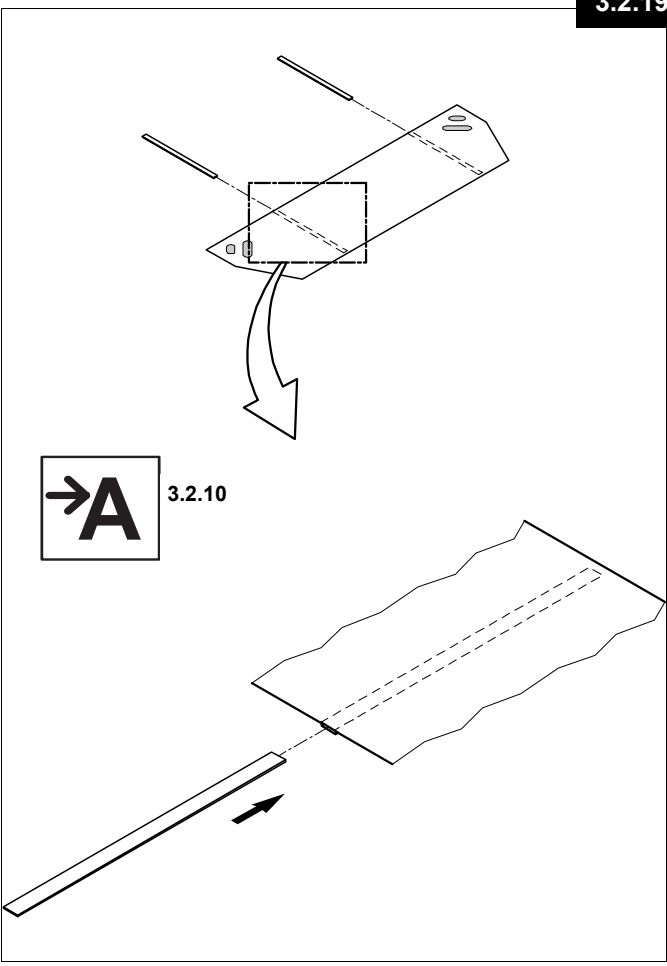

3.3.01

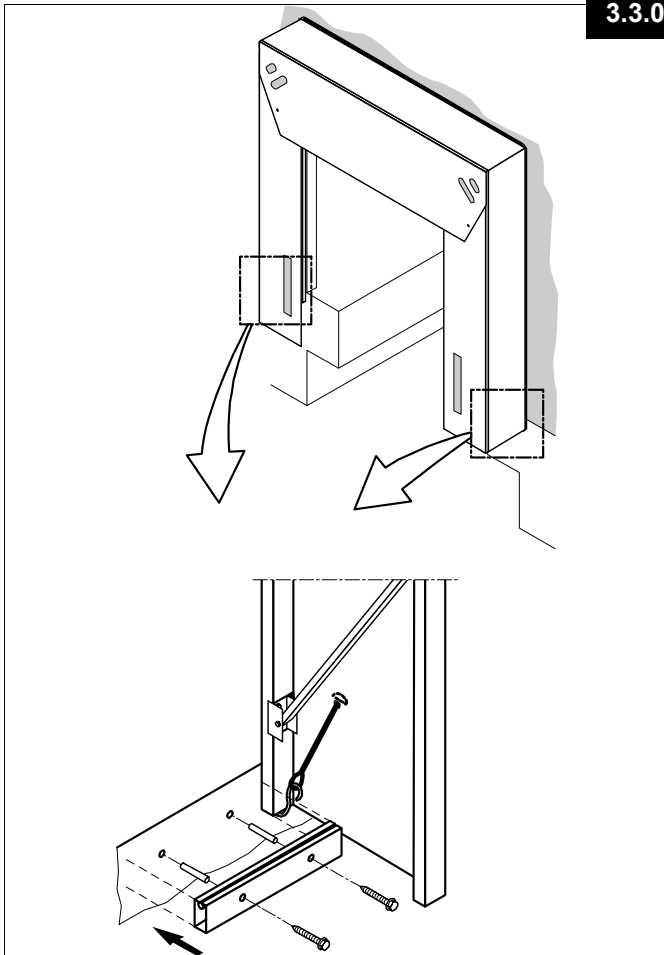

3.3.01-1

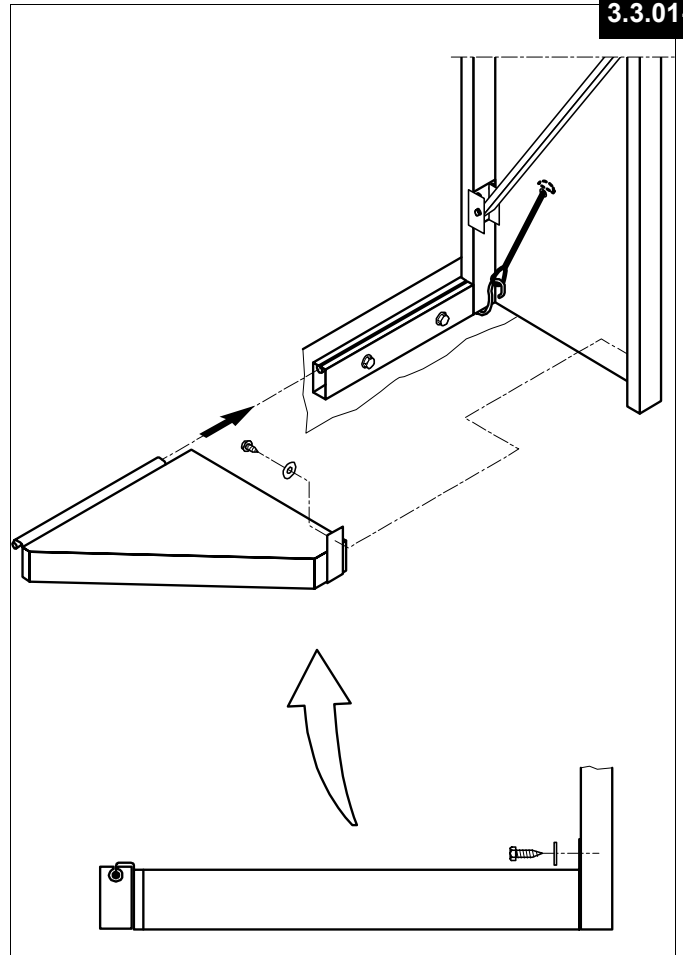

3.3.02

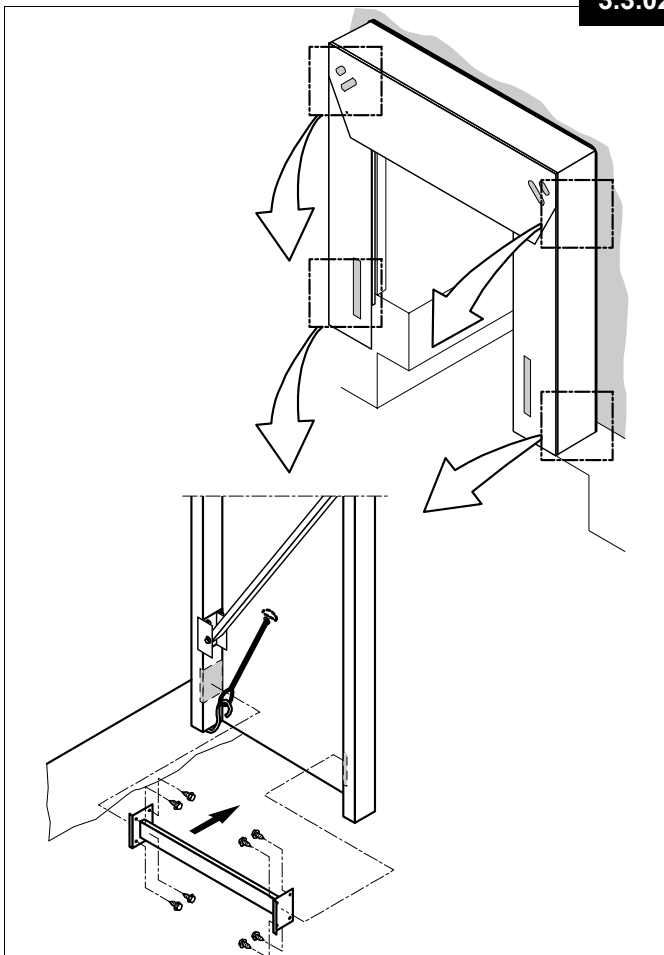

3.3.03

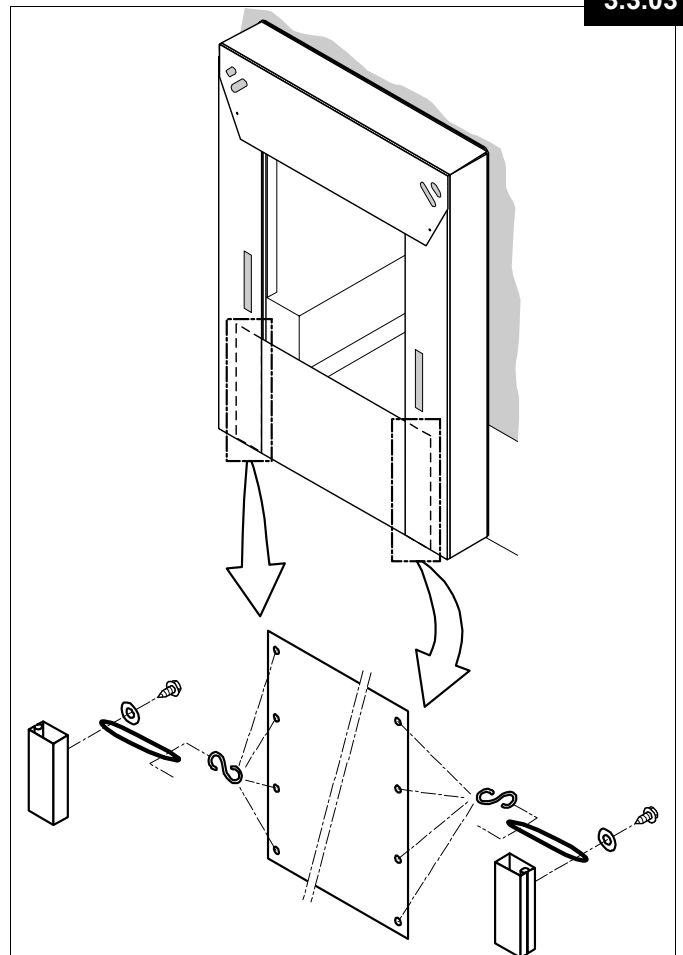

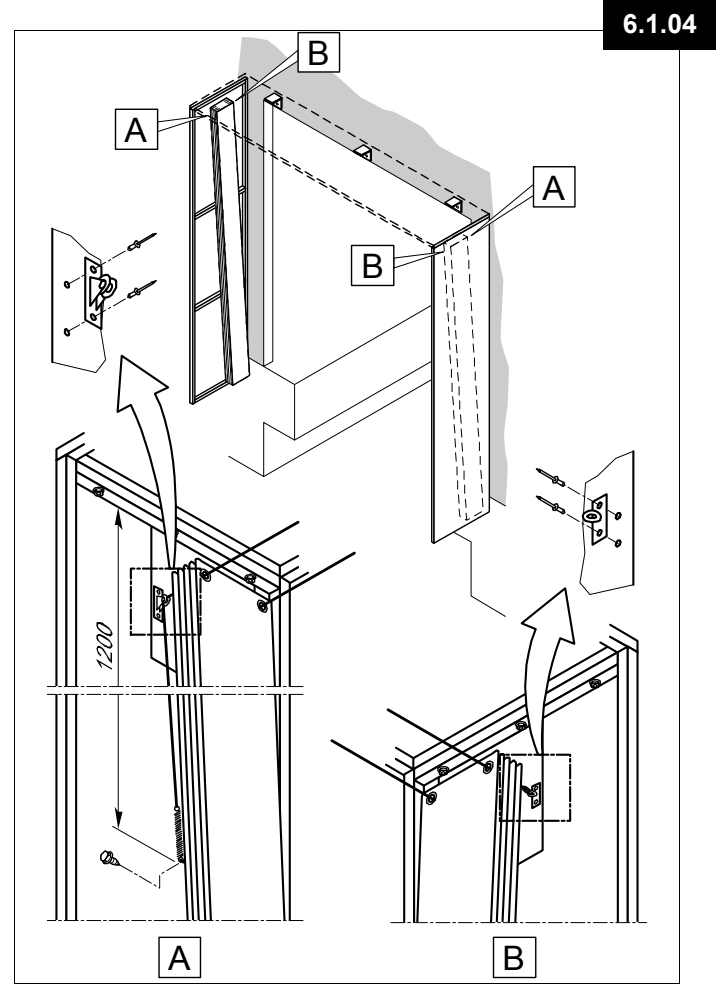
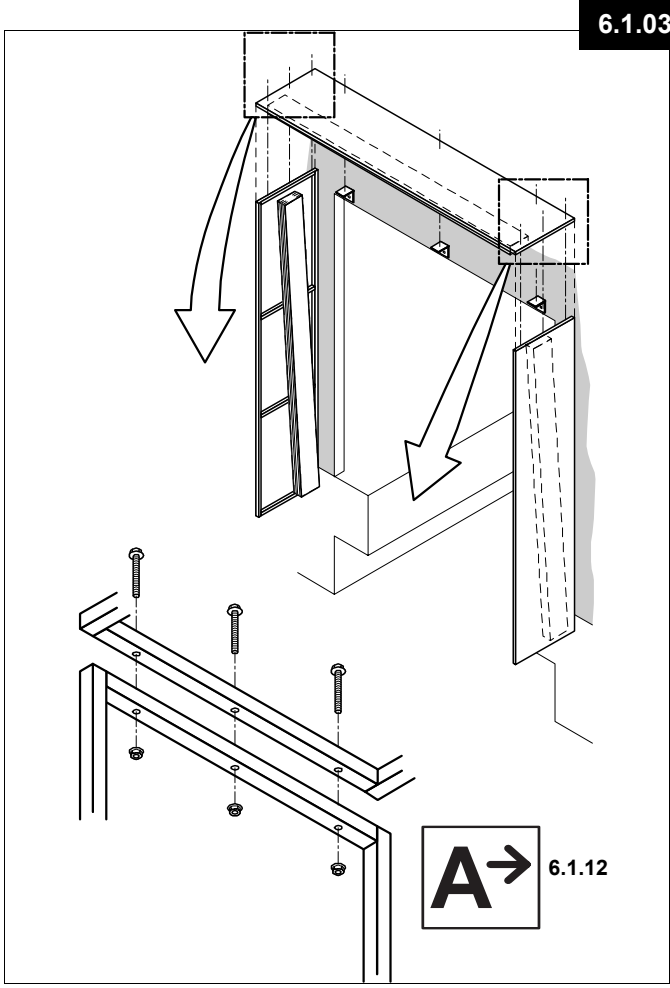
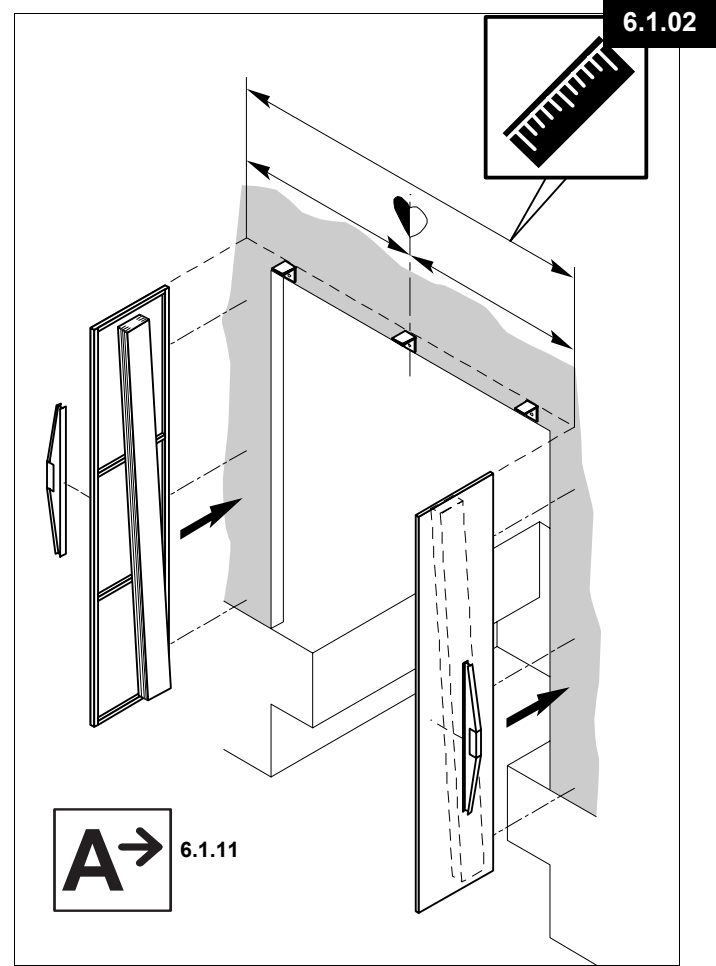
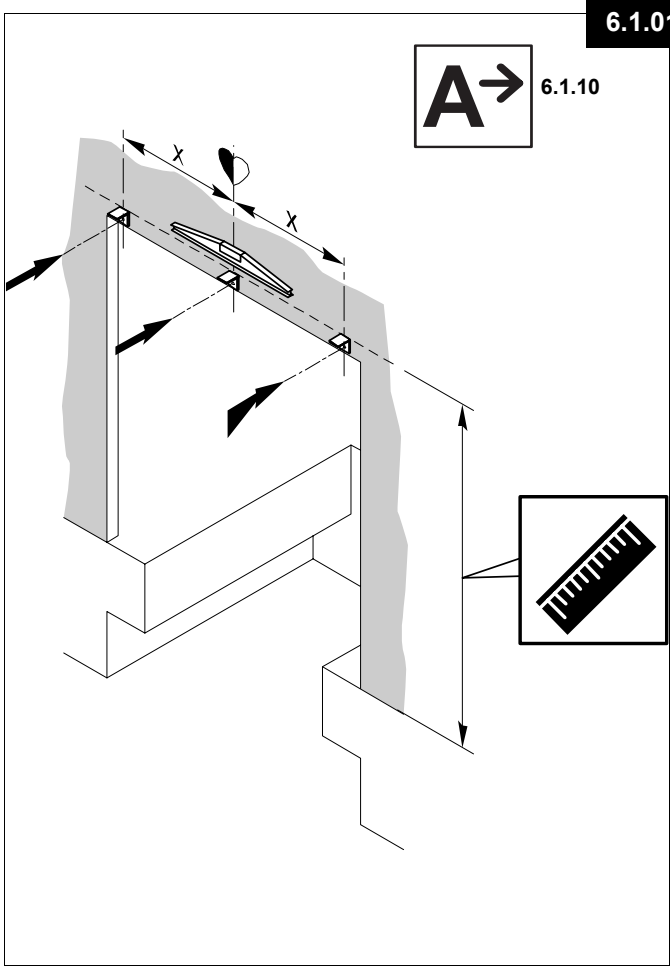

6.1.05

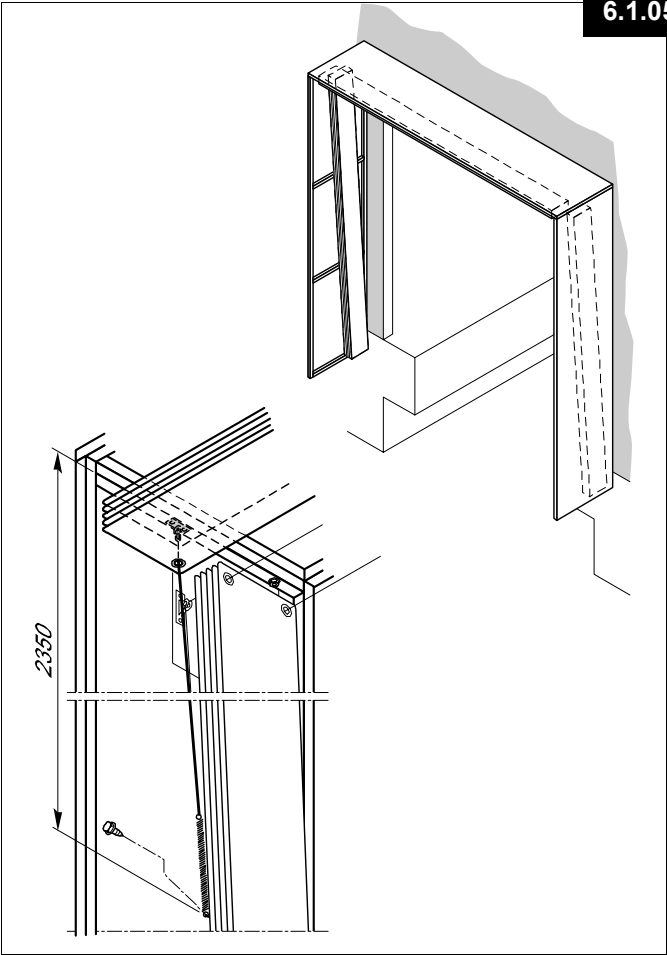

6.1.06

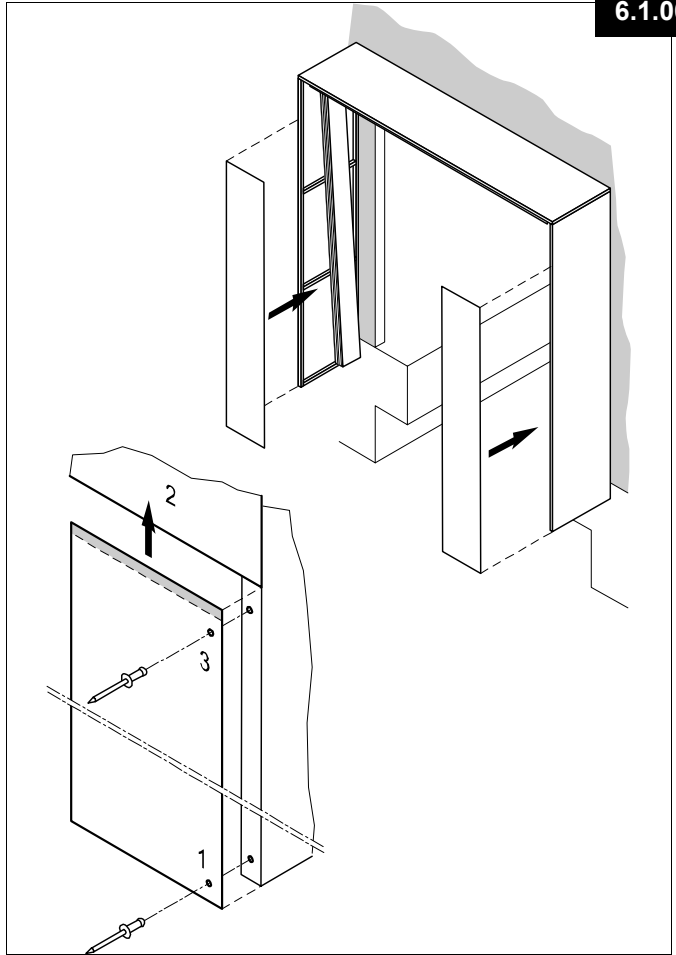

6.1.07

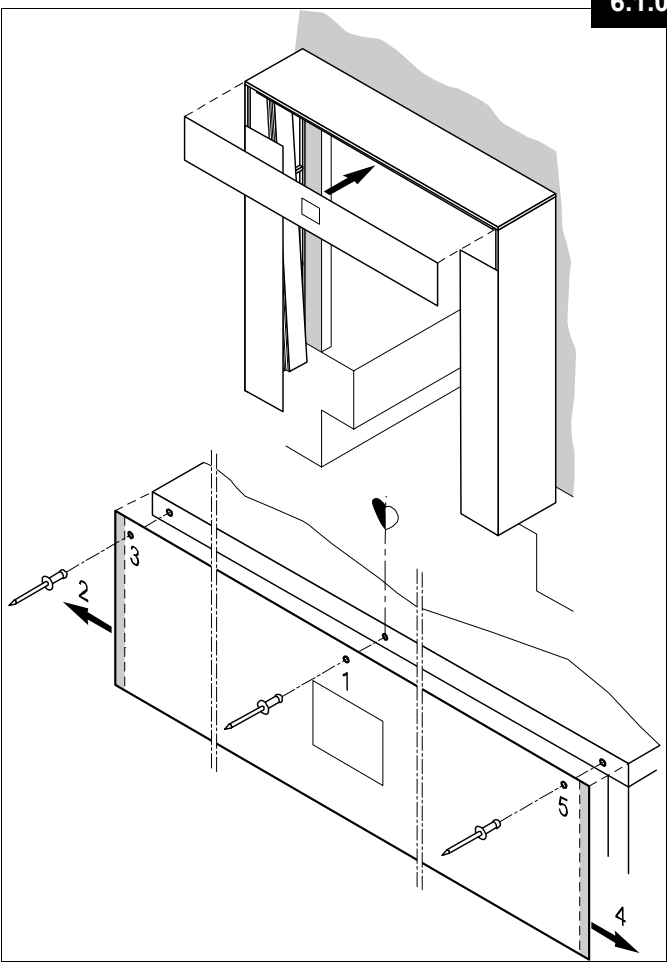

6.1.08

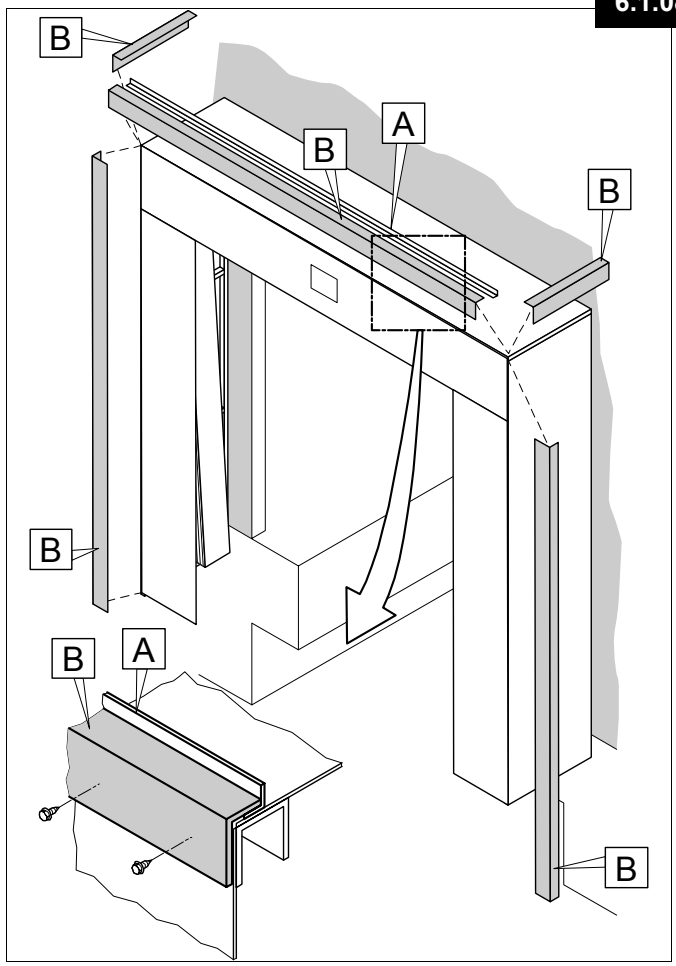

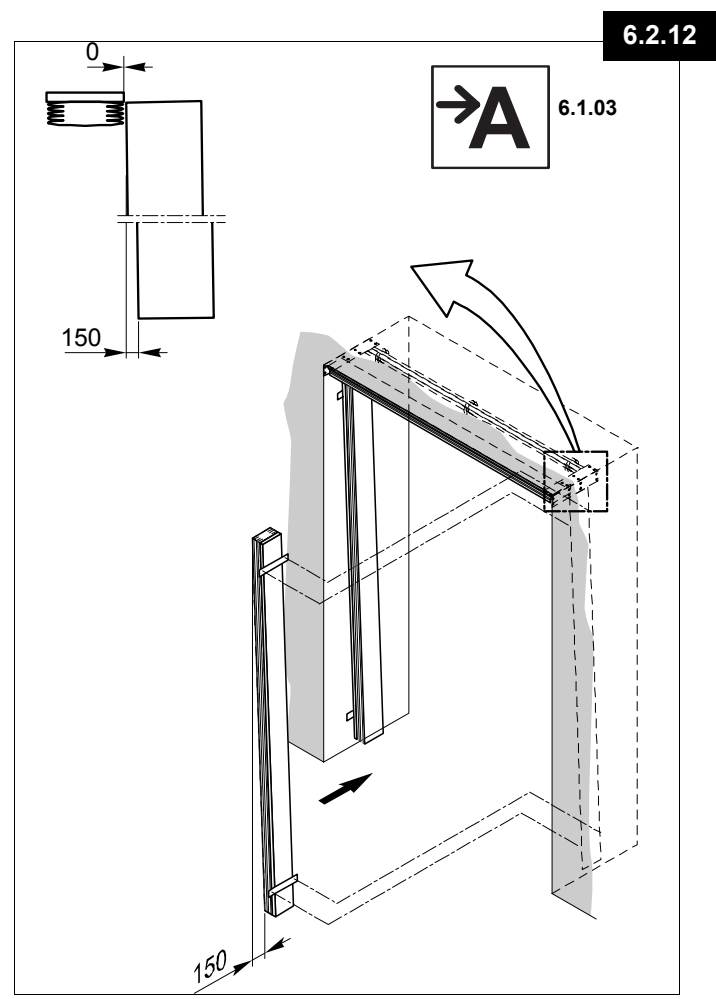
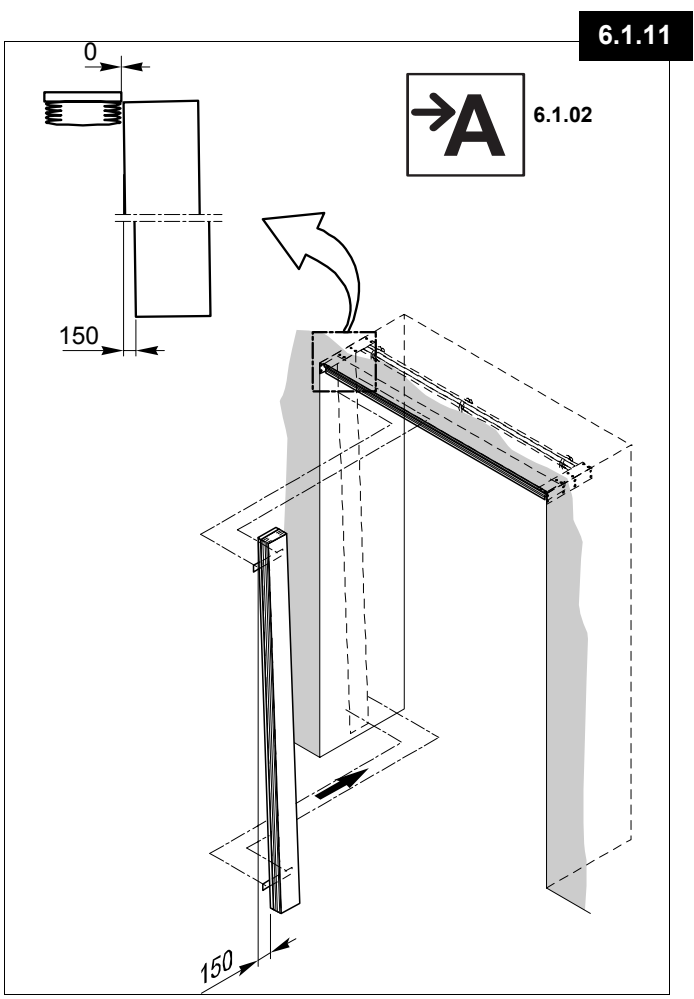
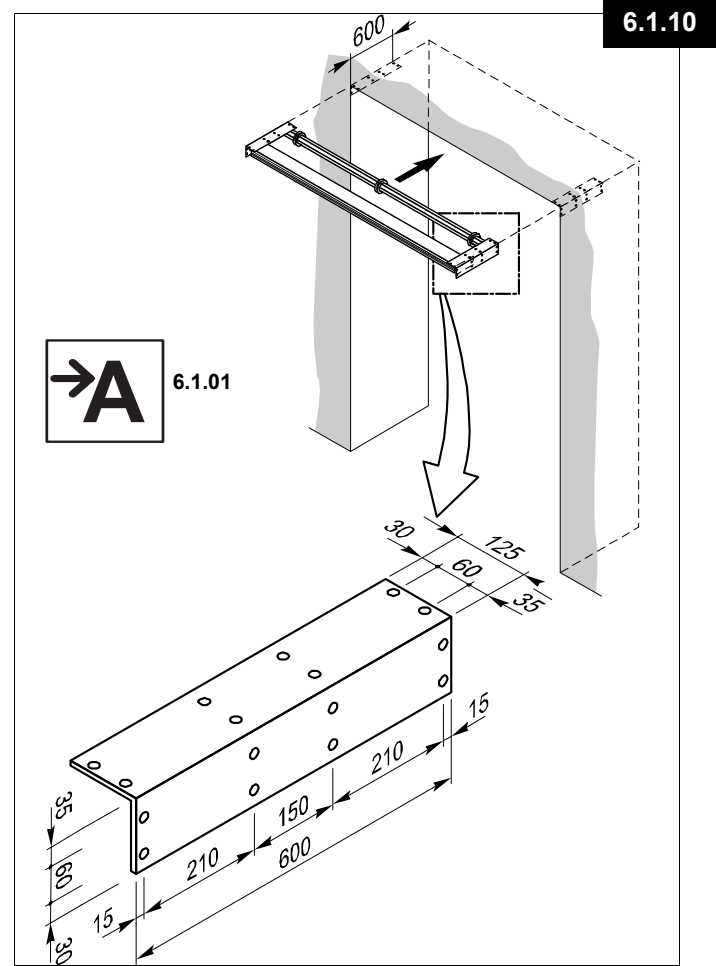
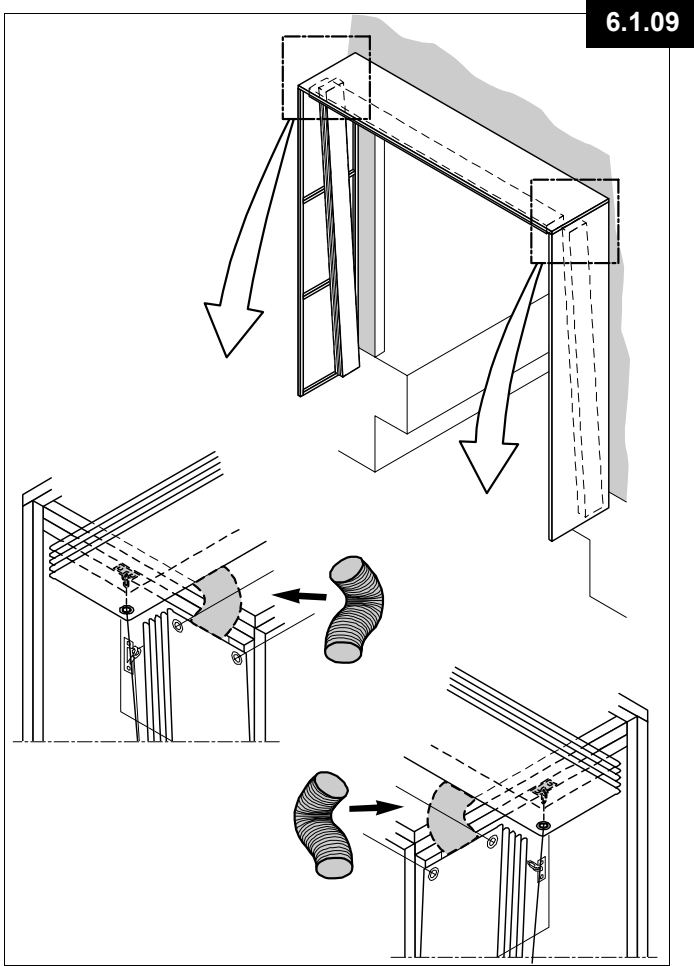

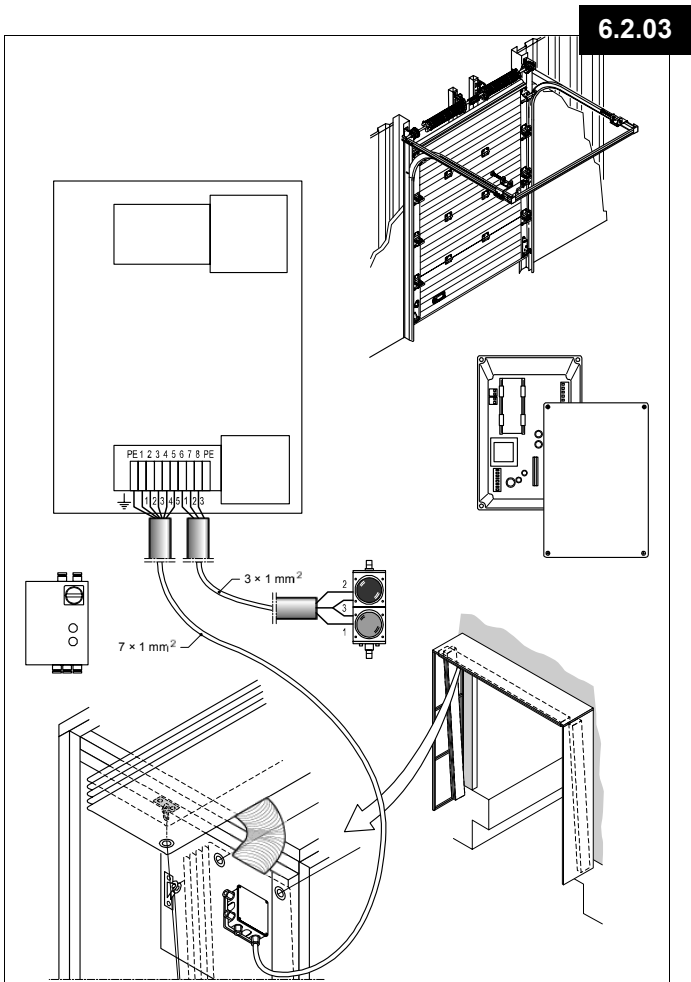
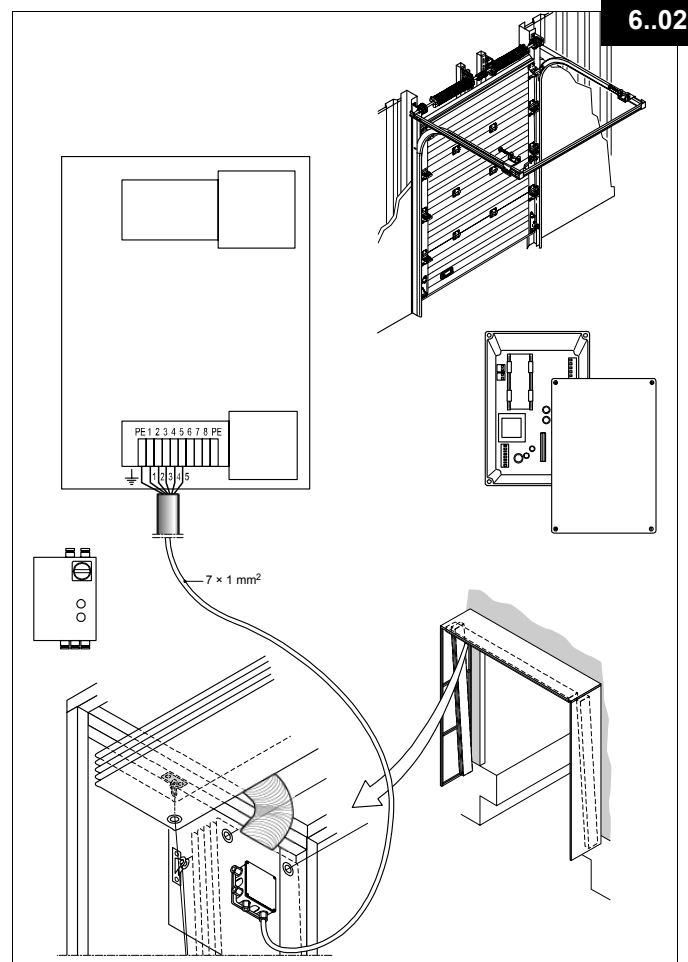
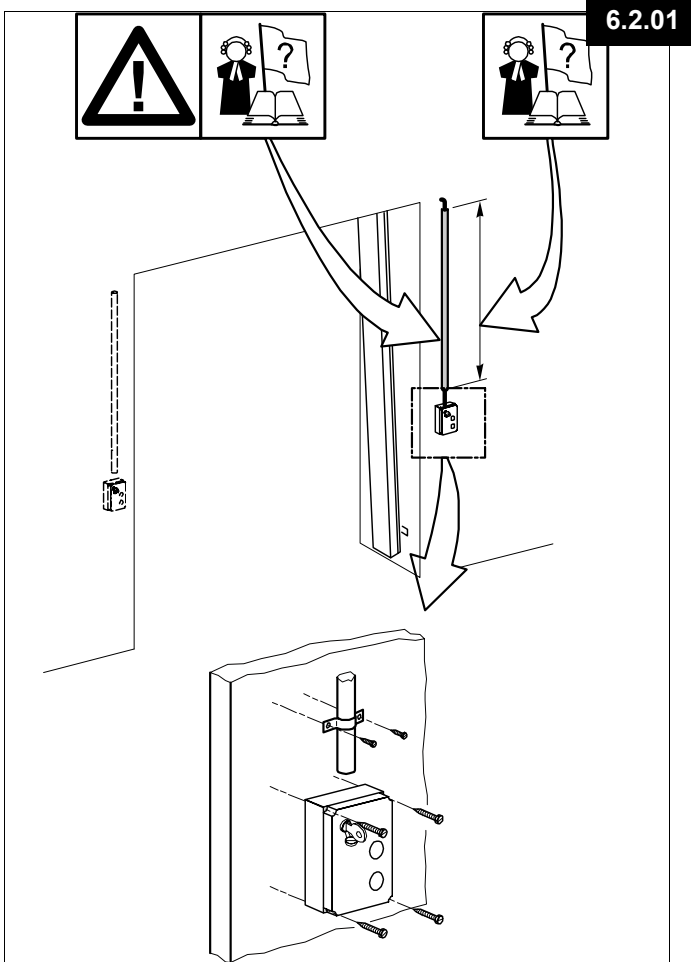

6.3.01

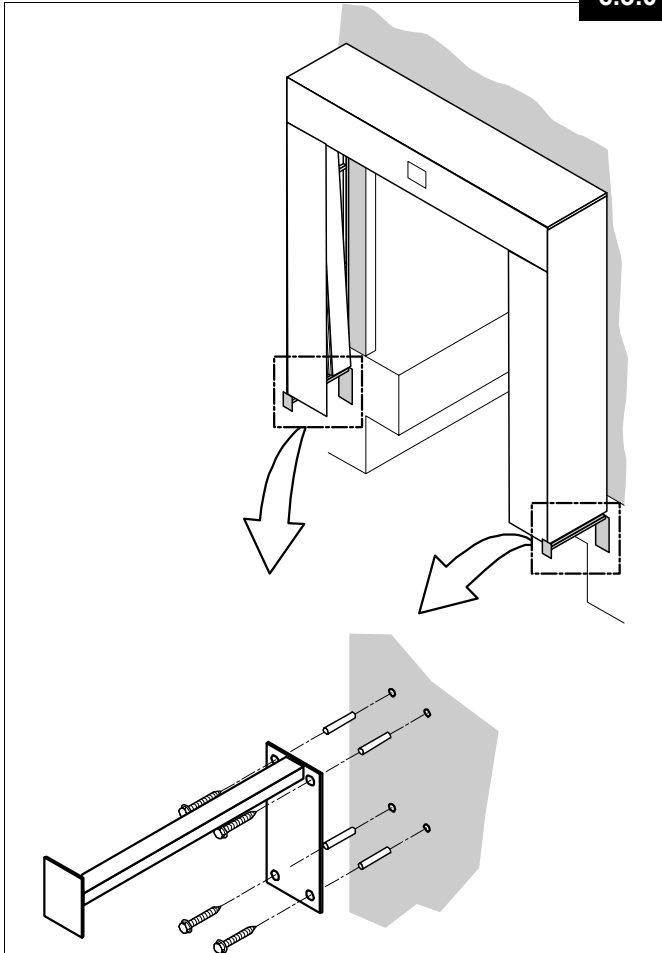

6.3.02

